

 LIENZOS®

# Wallmurals



GREENHOUSE



# GREENHOUSE

**GARDEN GLORY** 4-25

Kollektionen Greenhouse är en hyllning till naturens kraft och mångfald. Till ogräsen som vägrar ge upp, maskrosorna som växer genom asfalten och taggiga rosenbuskar som inte låter sig tuktats.

**ONE OF A KIND** 26-43

Greenhouse är tapeter för de som vågar växa fritt.

.....

**FOREST ESCAPADES** 44-57

The Greenhouse collection is a tribute to the power and diversity of nature. It's for the weeds that won't stop grow, the dandelions that burst through asphalt and the thorny rose bush that refuse to be tamed.

**STRUCTURED CREATIVITY** 58-71

Greenhouse is a collection for those who dare to grow free.

# GREENHOUSE

ARTIKEL NR   ARTICLE NO	NAMN   NAME	SIDA   PAGE	ARTIKEL NR   ARTICLE NO	NAMN   NAME	SIDA   PAGE
R12941	Frost Leaf	50-51	R13111	Make It Bloom	20-21
R12961	Lay In The Hay	54-55	R13121, R13122, R13123	Lily Pond	64-65
R12971	Scandinavian Light	52-53	R13131, R13132	Flowerbed	8-9
R12991	Simple Seedpod	24-25	R13141	Meadow	6-7
R13001	Blossom For The Bees	16-17	R13151	Poppy Art Andy	62-63
R13021	Old Pine Trees	56-57	R13161	Poppy Art	14-15
R13031	Birch Trunks	48-49	R13171, R13172	Fruit & Flora	34-35
R13041	Welcome To The Jungle	46-47	R13181	Wall Garden	40-41
R13051	Bellewood	30-31	R13191, R13192	ABC for the spelling bee	10-11
R13053, R13054, R13055, R13056	Bellewood Toile	32-33	R13193, R13194	ABC for the Swedish bee	10-11
R13061, R13062	La Vie En Tulipe	22-23	R13201, R13202, R13203, R13204	Florigami	66-67
R13071, R13072	Rosegarden	38-39	R13211	Growing Wild	42-43
R13073	Thorn Rose	36-37	R13212	Growing Wilderness	42
R13081	Concrete Roses	68-69	R13221, R13222	Winding Spring	12-13
R13091, R13092	Summer Wind	18-19	R13231	Harlequin Roses	70-71
R13101, R13102	Flower Dot	60-61	R13241	Garden Gate	28-29

**GARDEN  
GLORY**





LA VIE EN TULIPE  
SIDA/PAGE: 22-23

ABC FOR THE SPELLING BEE  
SIDA/PAGE: 10-11



FLOWERBED  
SIDA/PAGE: 8-9



MEADOW  
SIDA/PAGE: 6-7

## GARDEN GLORY

A garden is a place of hope, it's where dreams are grown. Nothing is everlasting and therefore even more beautiful. It's a place where you live in the present and plan for tomorrow.

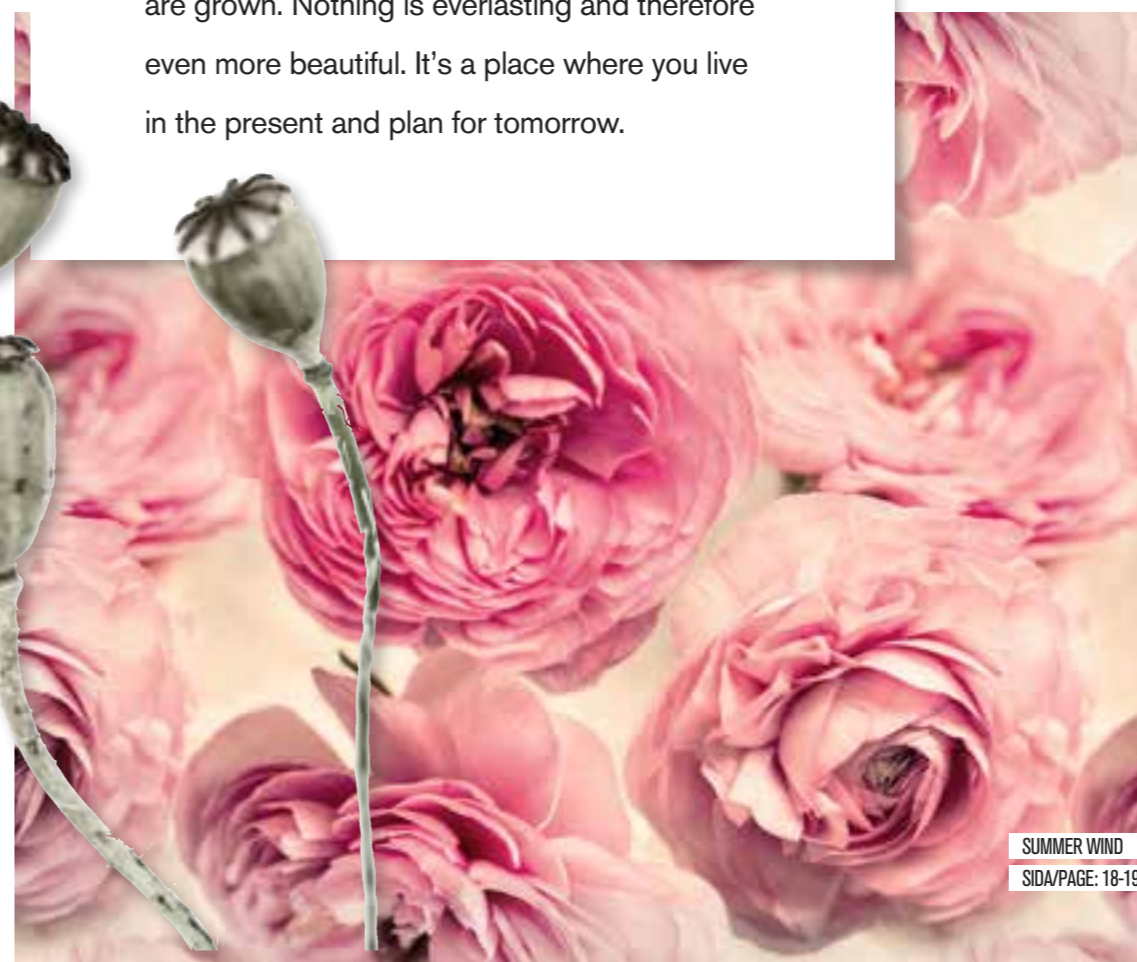

SUMMER WIND  
SIDA/PAGE: 18-19



# MEADOW

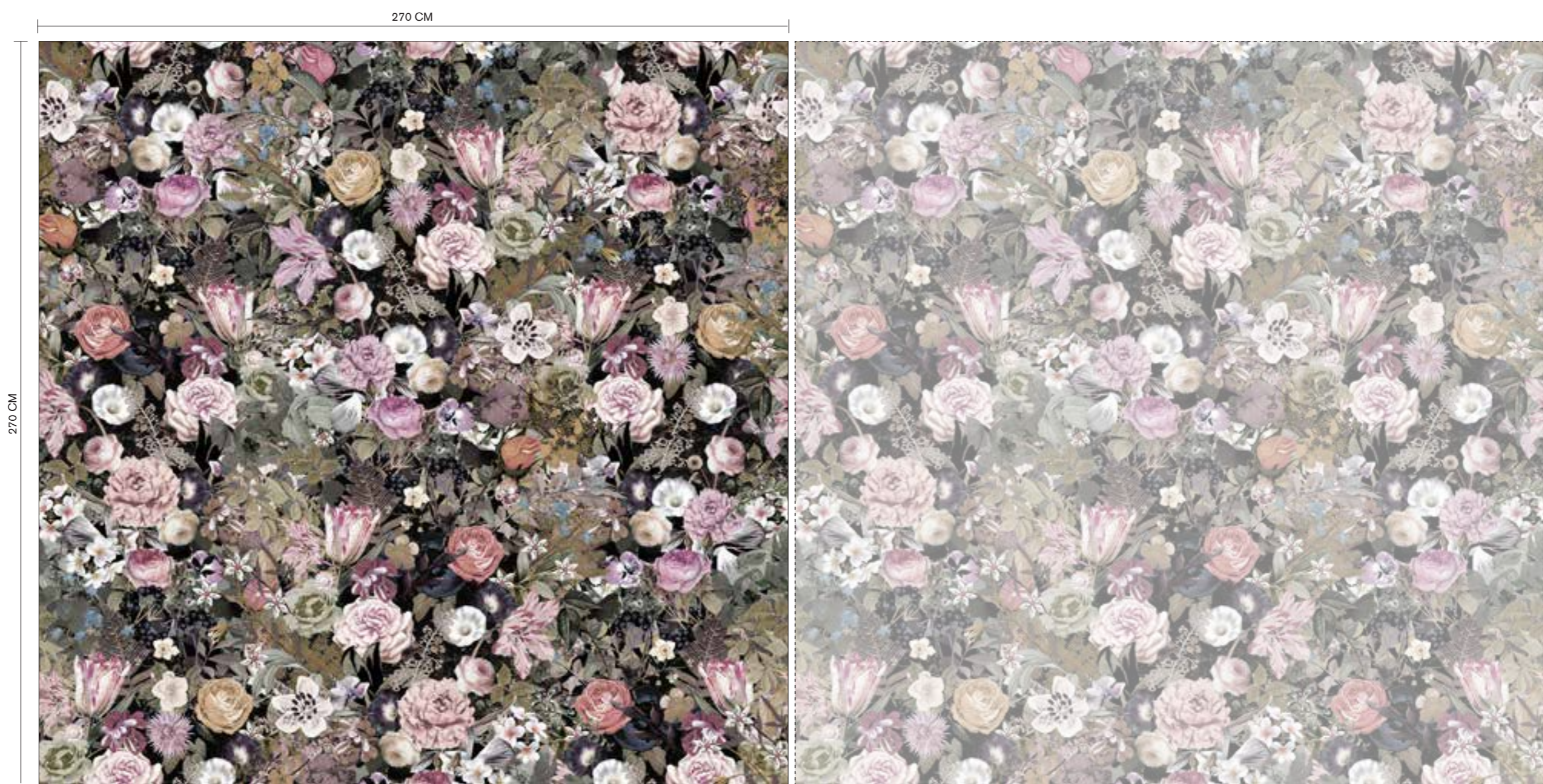

R13141-6 | MEADOW | 270x270 CM

**R** REPETERBAR/REPEATABLE - FOR LARGER WALL THAN 270 CM, BUY 2 OR MORE MURALS







# FLOWERBED

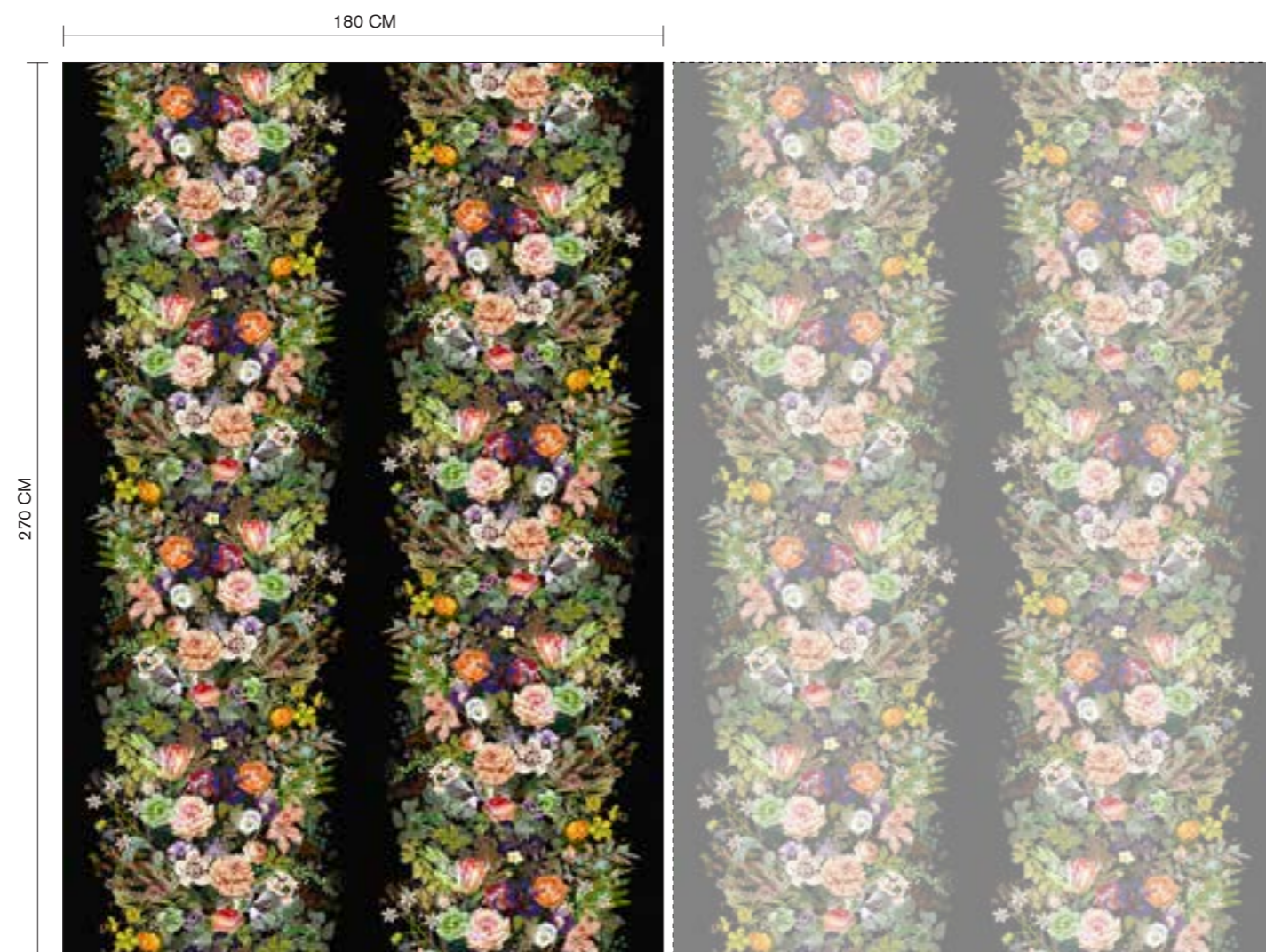

R13131-4 | FLOWERBED | 180X270 CM

**R** REPETERBAR/REPEATABLE - FOR LARGER WALL THAN 180 CM, BUY 2 OR MORE MURALS

Here we combine a classic striped wallpaper design with a colorful flowerbed of both handdrawn and real flowers. Use one or several panels to create a bombastic interior that blossoms all year round.



R13132-4 | FLOWERBED, VINTAGE | 180X270 CM

**R** REPETERBAR/REPEATABLE - FOR LARGER WALL THAN 180 CM, BUY 2 OR MORE MURALS







## ABC FOR THE SPELLING BEE



R13191-4 | ABC FOR THE SPELLING BEE | 180X270 CM



R13192-4 | ABC FOR THE SPELLING BEE, BLACK | 180X270 CM

Carefully handdrawn letters created with ink and watercolors. Nature herself had a say in the choice of plants for this alphabet wallpaper. Our illustrator picked only the flowers which shape naturally looked like a letter.

Tips! Hang it just as it is or use our design services to write something personal.



R13193-4 | ABC FOR THE SWEDISH BEE | 180X270 CM



R13194-4 | ABC FOR THE SWEDISH BEE, BLACK | 180X270 CM





A B C D E  
F G H I J  
K L M N O  
P Q R S T  
U V W X Y Z



# WINDING SPRING

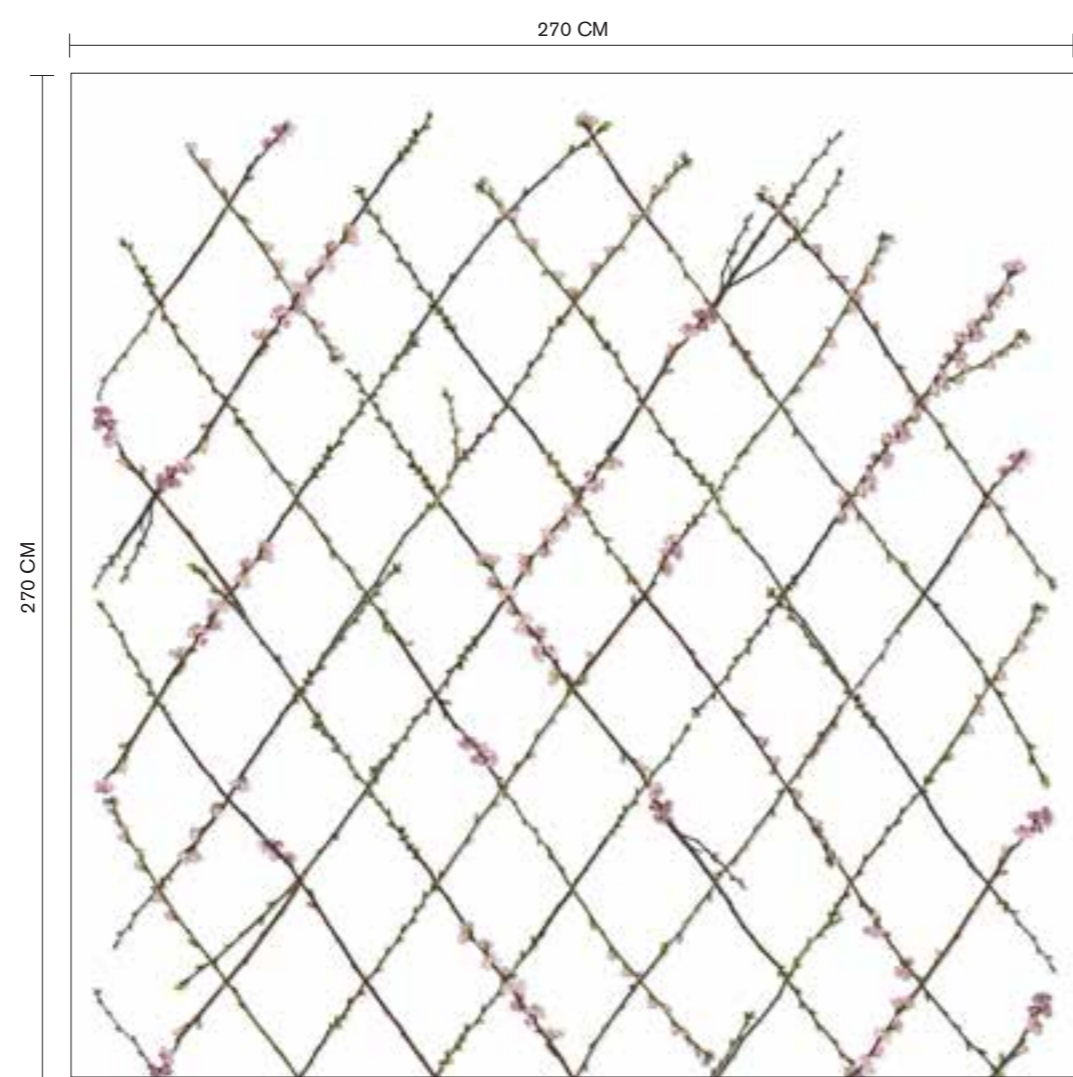

R13221-6 | WINDING SPRING | 270x270 CM

When spring comes, everything changes and new ideas sprout. A different version of a classic trellis design came to life when our designer passed a vibrant cherry blossom tree on her way to the designstudio a beautiful spring morning.

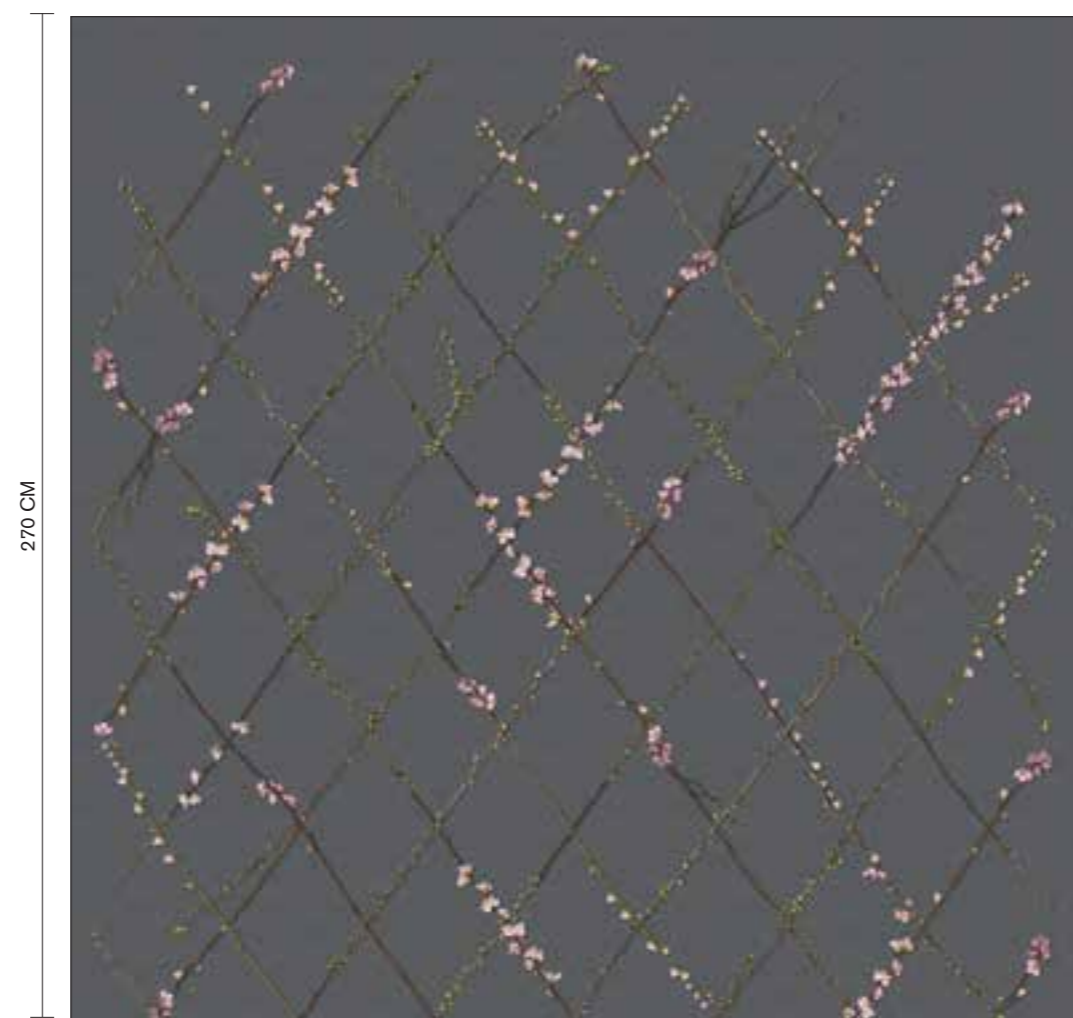

R13222-6 | WINDING SPRING, BLACK | 270x270 CM







# POPPY ART

360 CM

270 CM



R13161-8 | POPPY ART | 360X270 CM







## BLOSSOM FOR THE BEES

360 CM



270 CM

R13001-8 | BLOSSOM FOR THE BEES | 360X270 CM



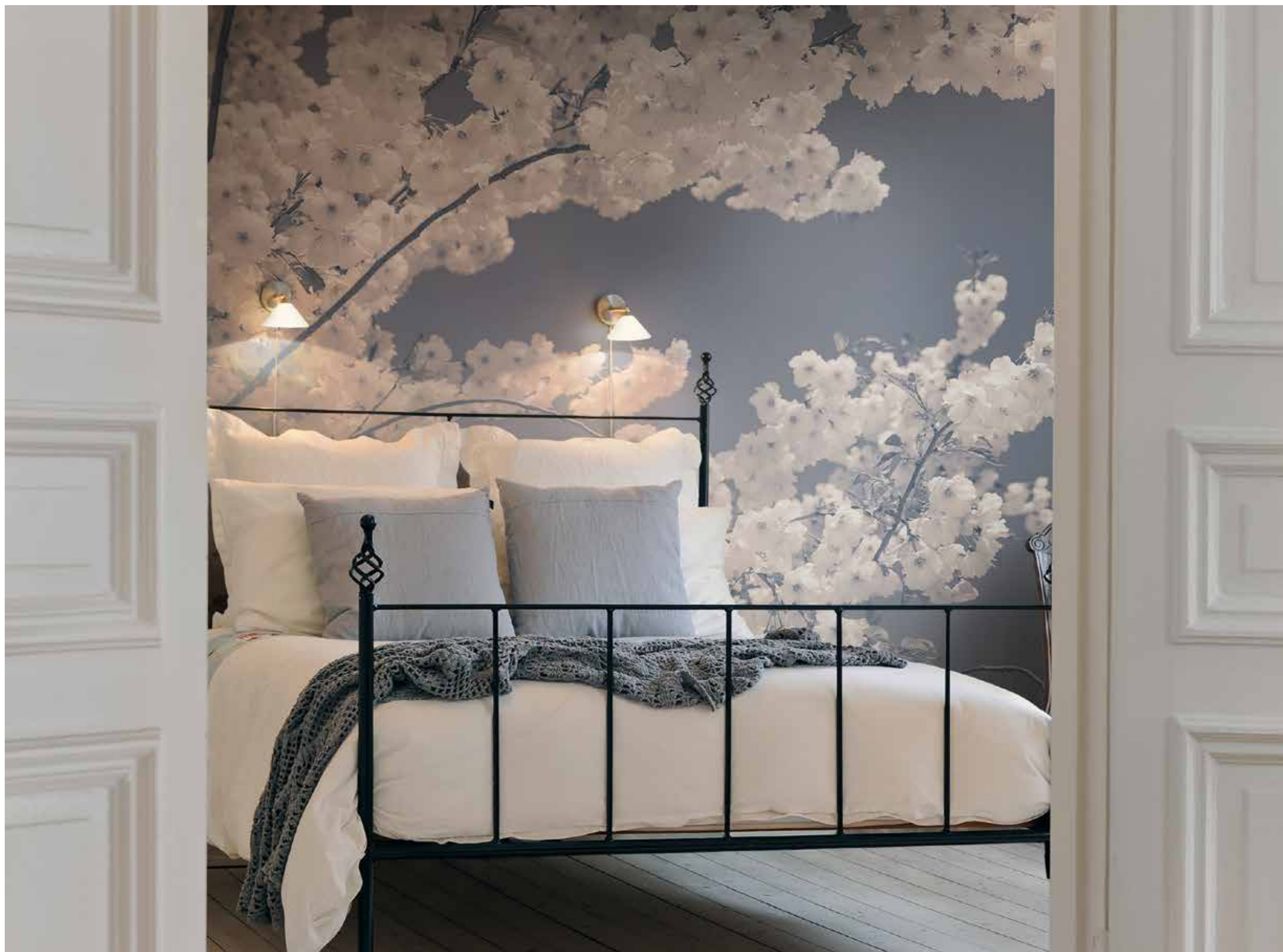



# SUMMER WIND

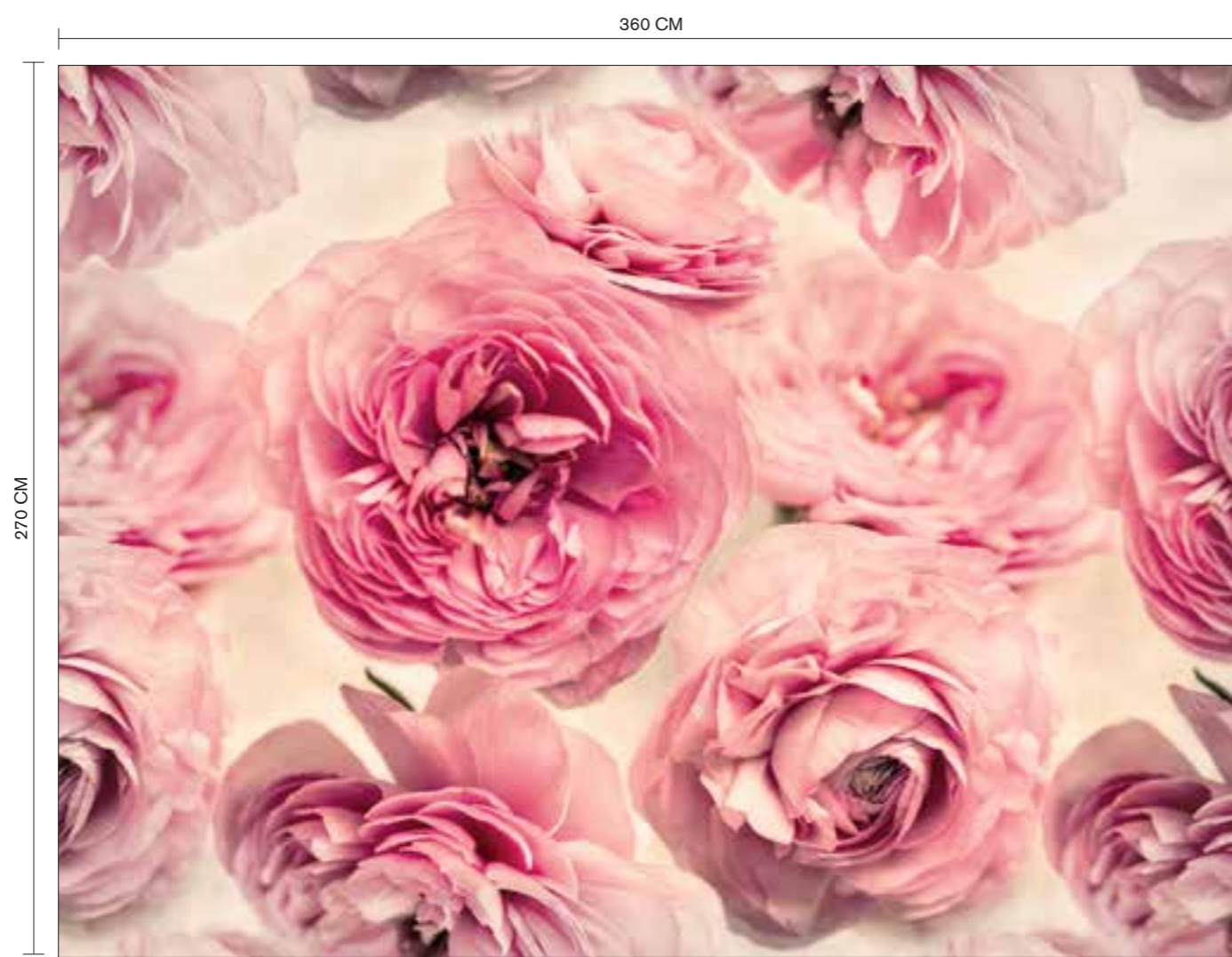

R13091-8 | SUMMER WIND | 360X270 CM



R13092-8 | SUMMER WIND, BLACK AND WHITE | 360X270 CM







# MAKE IT BLOOM



R13111-6 | MAKE IT BLOOM | 270x270 CM

**R** REPETERBAR/REPEATABLE - FOR LARGER WALL THAN 270 CM, BUY 2 OR MORE MURALS







## LA VIE EN TULIPE

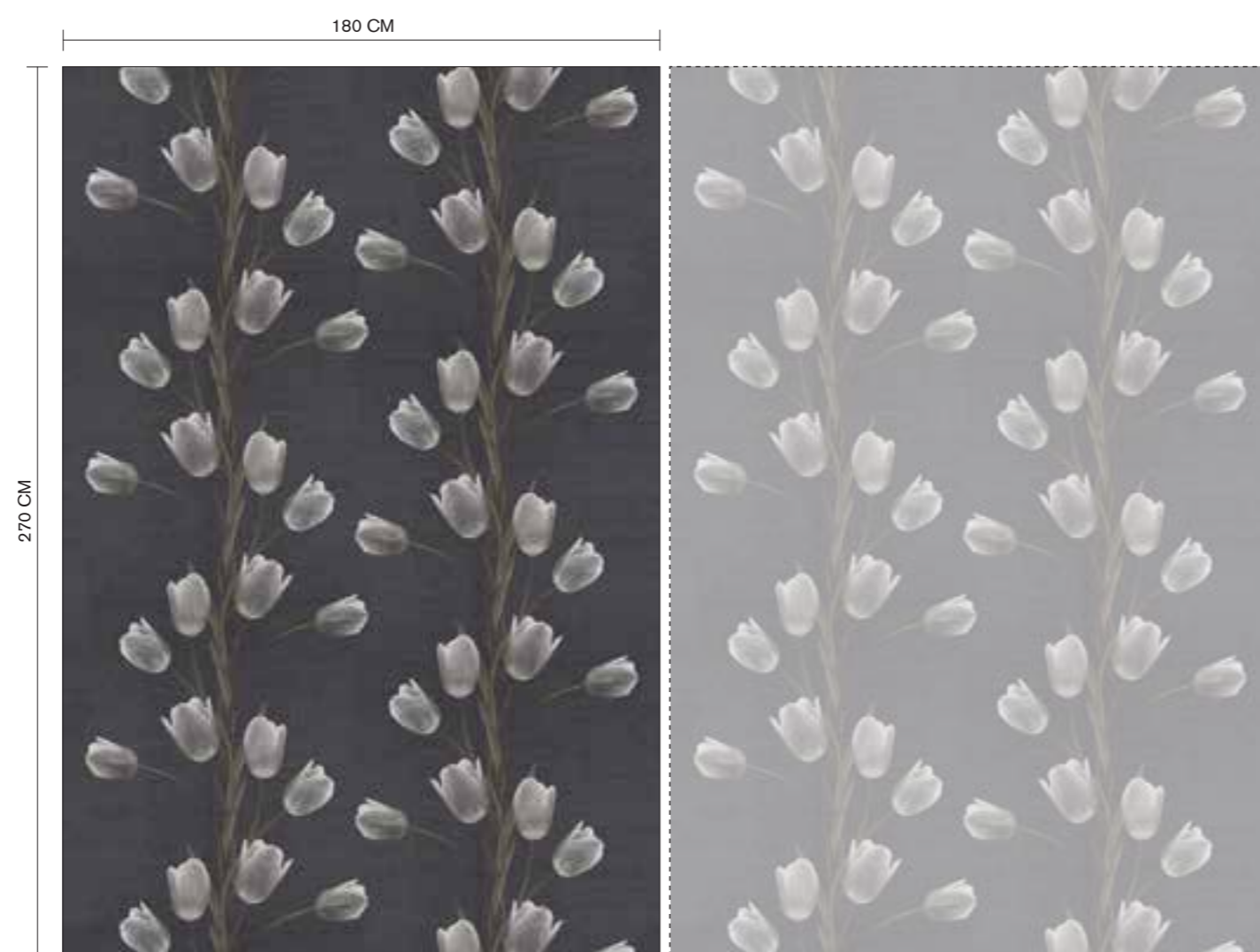

R13061-4 | LA VIE EN TULIPE, BLACK | 180X270 CM

**R** REPETERBAR/REPEATABLE - FOR LARGER WALL THAN 180 CM, BUY 2 OR MORE MURALS

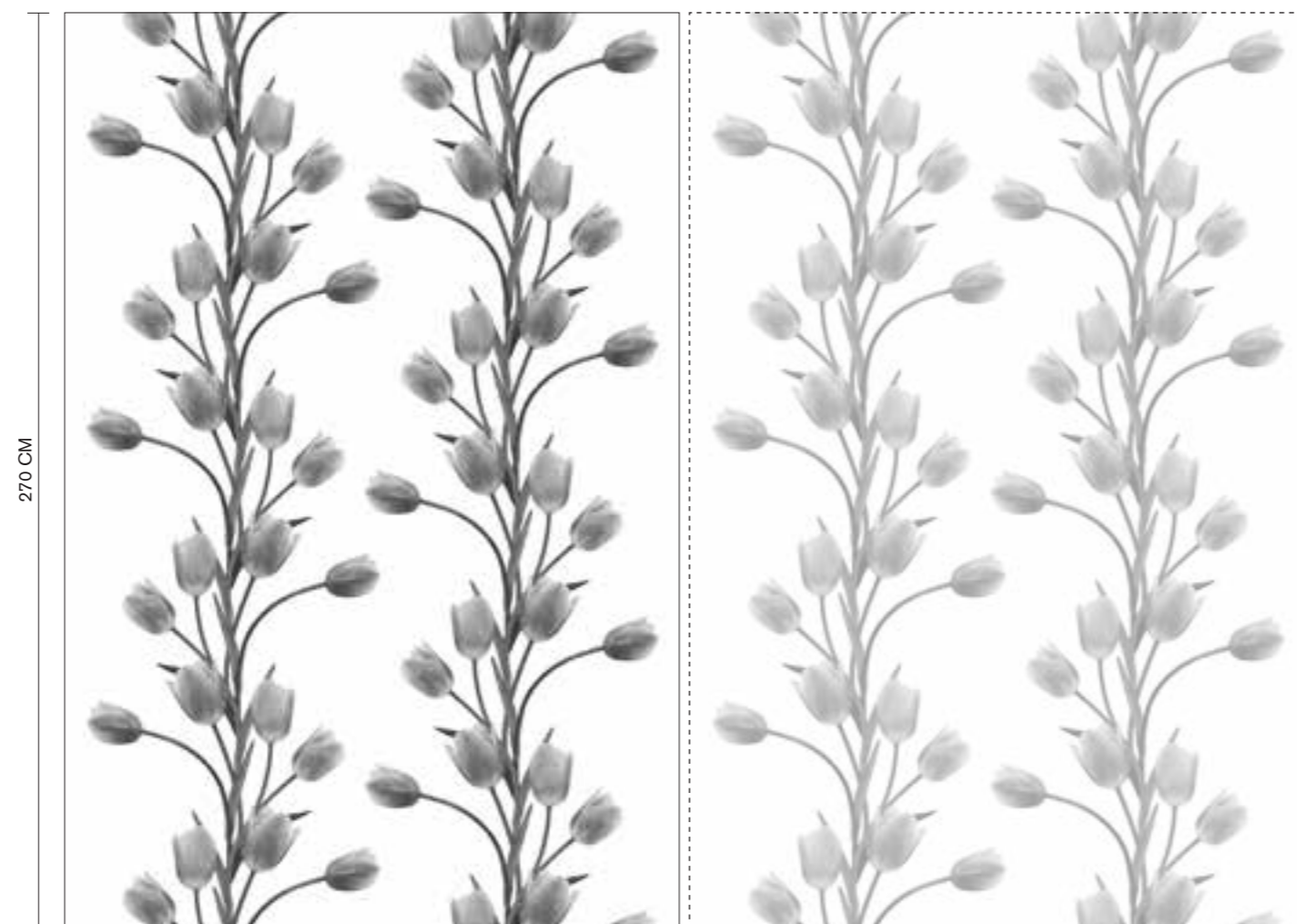

R13062-4 | LA VIE EN TULIPE, WHITE | 180X270 CM

**R** REPETERBAR/REPEATABLE - FOR LARGER WALL THAN 180 CM, BUY 2 OR MORE MURALS



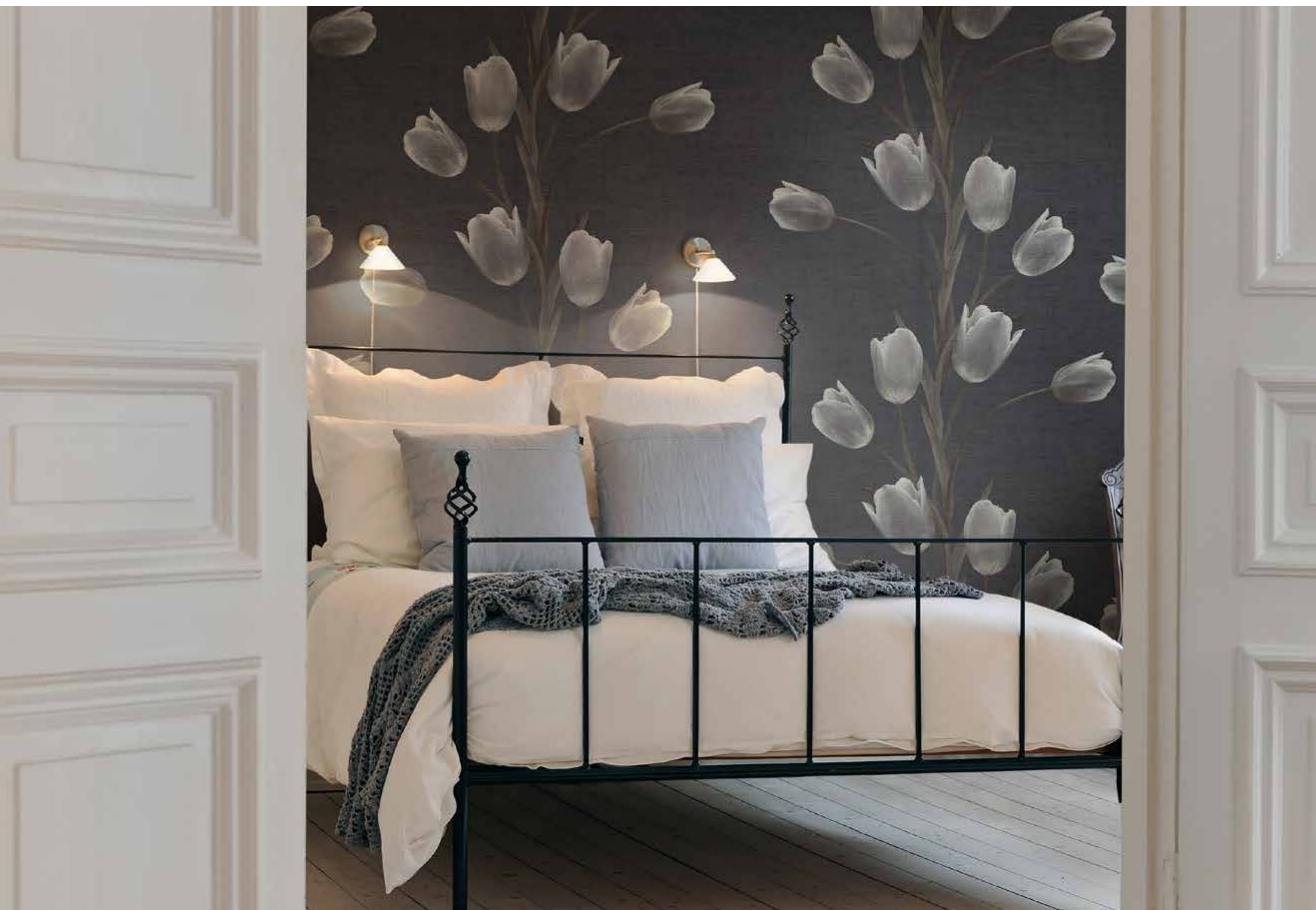



## SIMPLE SEEDPOD

360 CM



270 CM

R12991-8 | SIMPLE SEEDPOD | 360X270 CM







**ONE  
OF  
A  
KIND**





WALL GARDEN  
SIDA/PAGE: 40-41



THORN ROSE  
SIDA/PAGE: 36-37

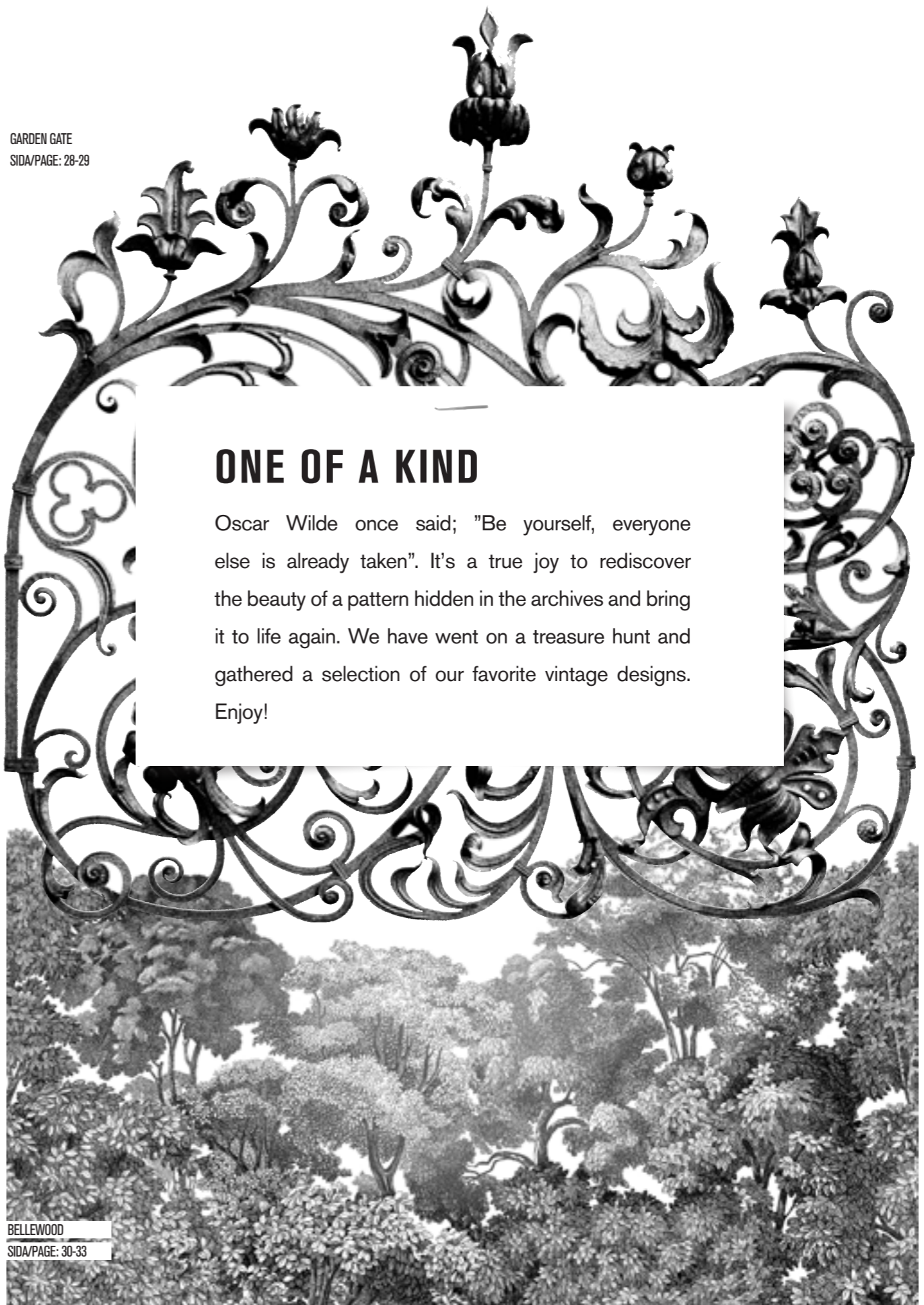

GARDEN GATE  
SIDA/PAGE: 28-29

## ONE OF A KIND

Oscar Wilde once said; "Be yourself, everyone else is already taken". It's a true joy to rediscover the beauty of a pattern hidden in the archives and bring it to life again. We have went on a treasure hunt and gathered a selection of our favorite vintage designs. Enjoy!

BELLENWOOD  
SIDA/PAGE: 30-33



# GARDEN GATE

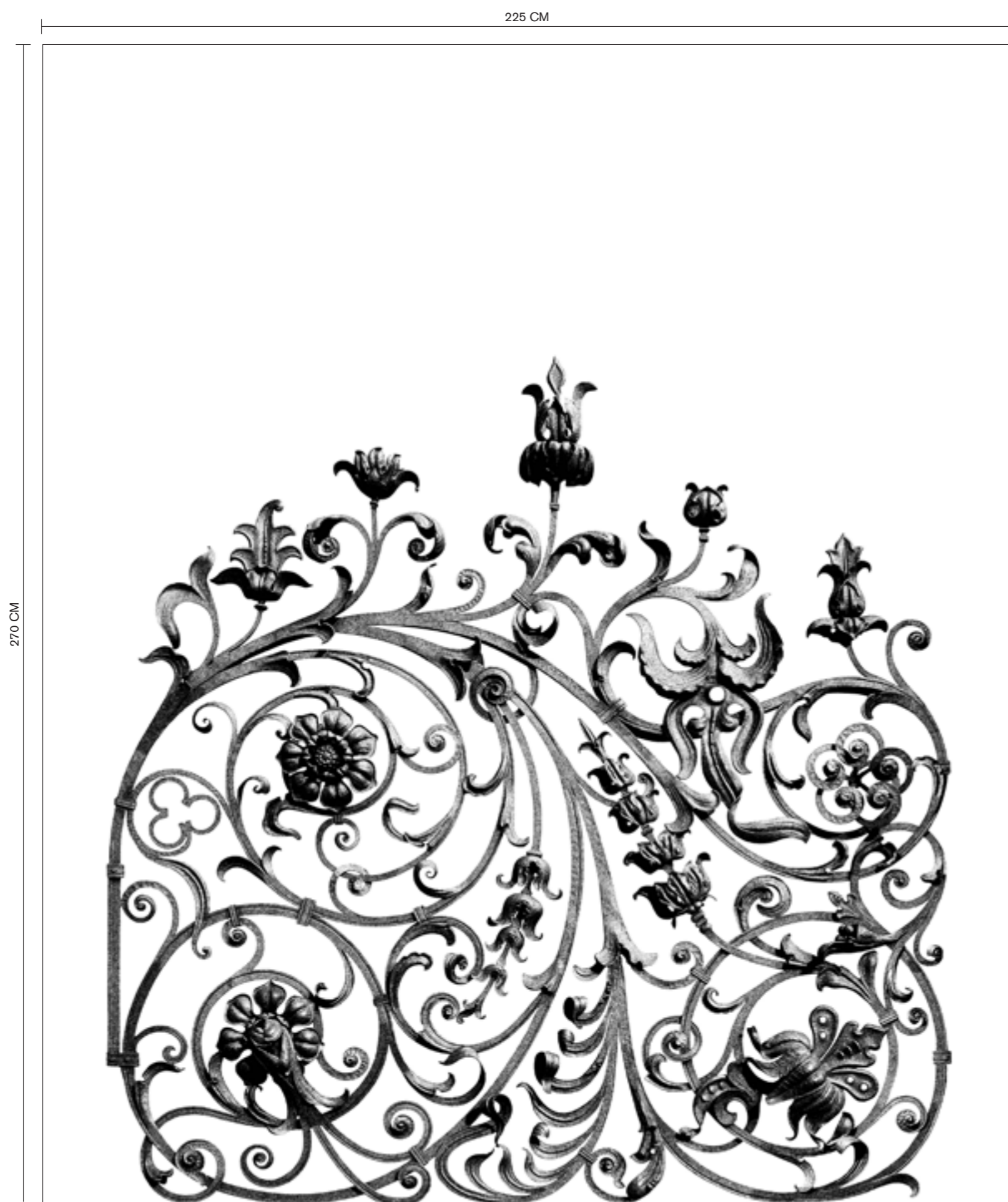

R13241-5 | GARDEN GATE | 225X270 CM

Tips! When you hang this glorious Garden Gate remember to start hanging it from the floor and up to get the best result.







# BELLEWOOD

360 CM

270 CM



R13051-8 | BELLEWOOD | 360X270 CM  REPETERBAR/REPEATABLE - FOR LARGER WALL THAN 360 CM, BUY 2 OR MORE MURALS

The inspiration for Bellewood comes from classic toile patterns. We wanted to create a modern toile made with traditional craftsmanship. Since the pattern is made to be repeated you can have the forest surround you completely. Or let it be a focal point by hanging it on one wall.

Tips! Use our design services to add personal details to the trees. Like names inscribed in the tree trunks.



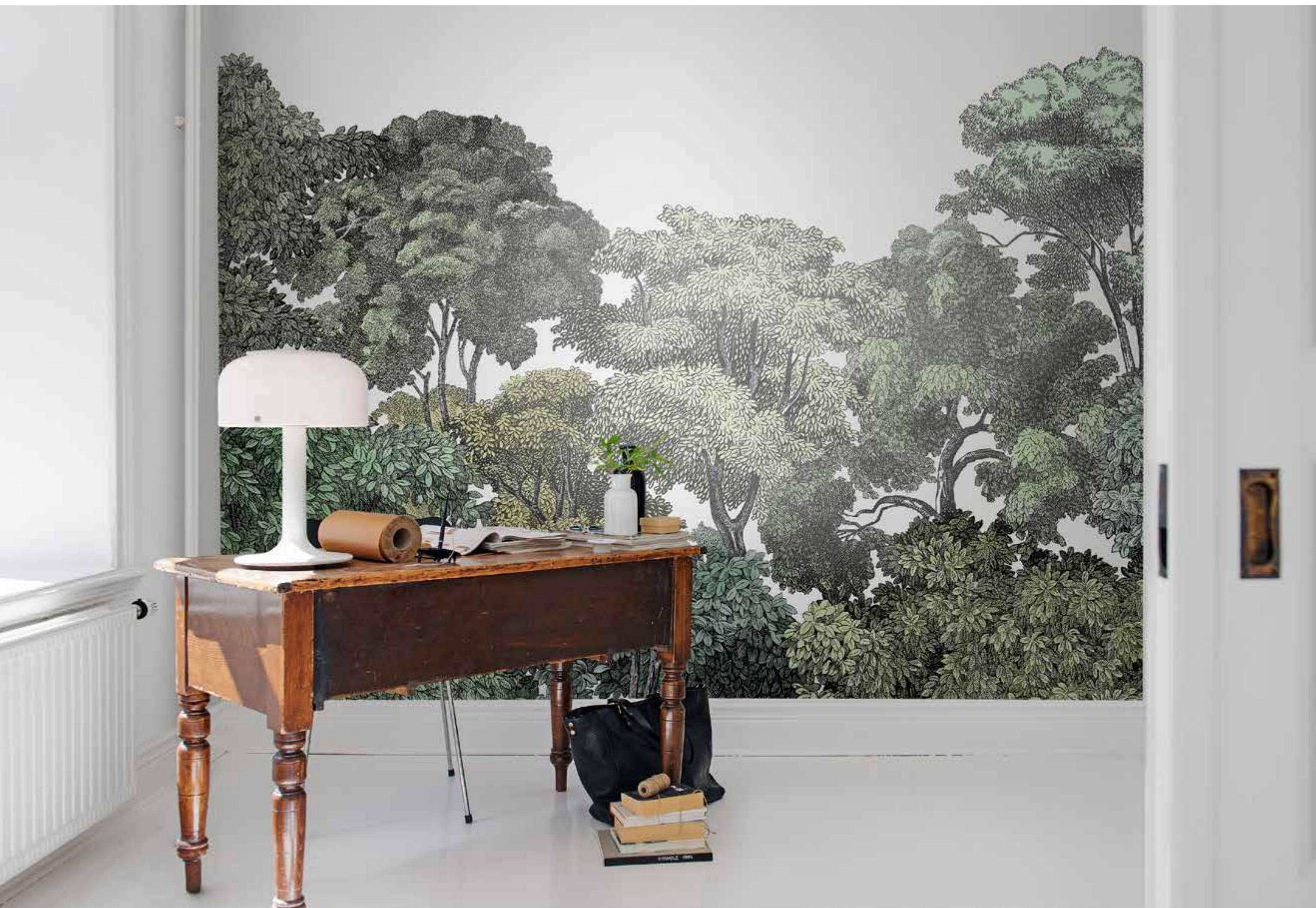



# BELLEWOOD



R13053-8 | BELLEWOOD, BLACK TOILE | 360X270 CM



REPETERBAR/REPEATABLE - FOR LARGER WALL THAN 360 CM, BUY 2 OR MORE MURALS

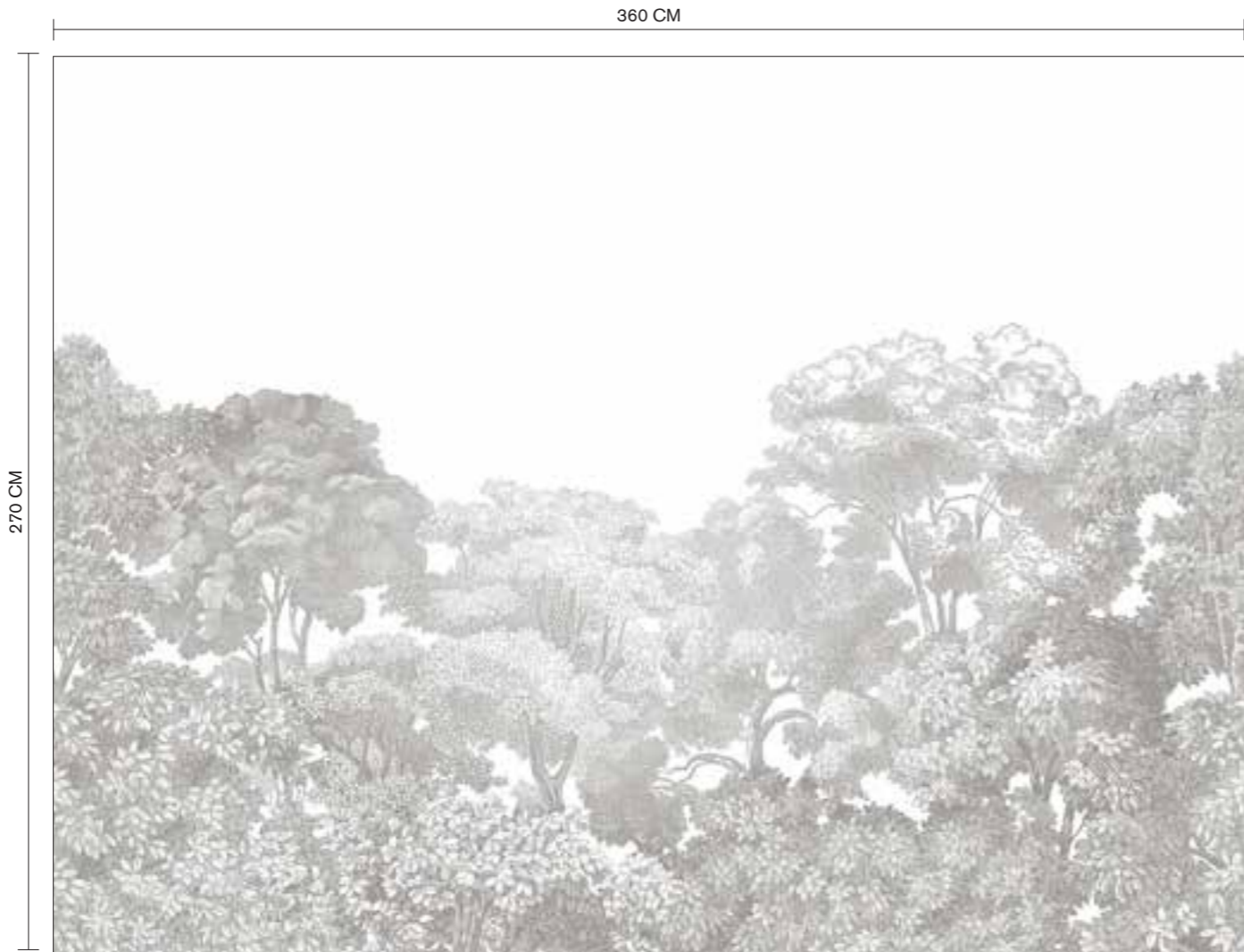

R13054-8 | BELLEWOOD, GREY TOILE | 360X270 CM



REPETERBAR/REPEATABLE - FOR LARGER WALL THAN 360 CM, BUY 2 OR MORE MURALS





R13055-8 | BELLEWOOD, PORCELAIN TOILE | 360X270 CM



REPETERBAR/REPEATABLE - FOR LARGER WALL THAN 360 CM, BUY 2 OR MORE MURALS



R13056-8 | BELLEWOOD, CRIMSON TOILE | 360X270 CM

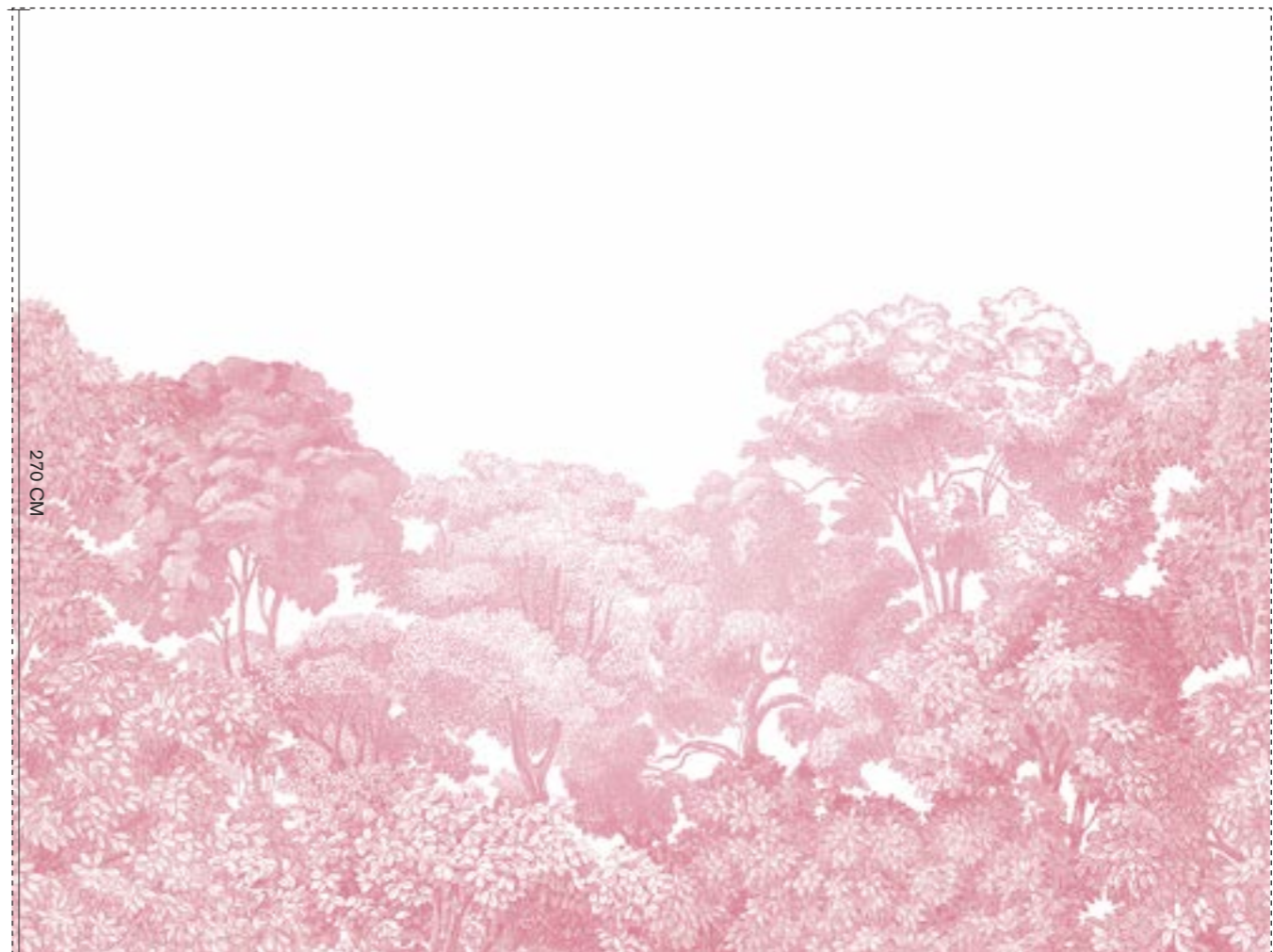

REPETERBAR/REPEATABLE - FOR LARGER WALL THAN 360 CM, BUY 2 OR MORE MURALS



# FRUIT & FLORA

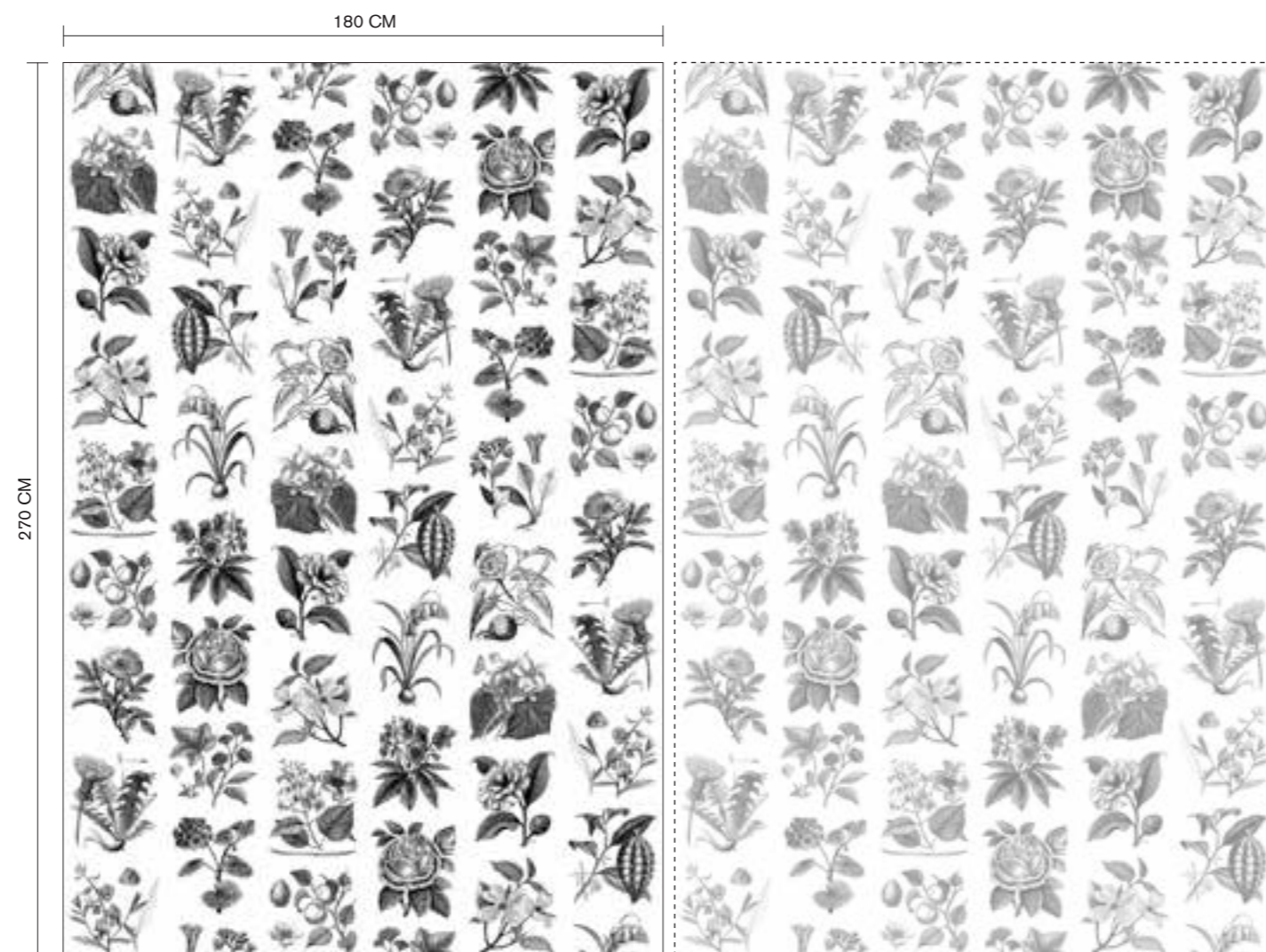

R13171-4 | FRUIT & FLORA | 180X270 CM

**R** REPETERBAR/REPEATABLE - FOR LARGER WALL THAN 180 CM, BUY 2 OR MORE MURALS



R13172-4 | FRUIT & FLORA, COLOR | 180X270 CM

**R** REPETERBAR/REPEATABLE - FOR LARGER WALL THAN 180 CM, BUY 2 OR MORE MURALS







# THORN ROSE

180 CM

270 CM



R13073-4 | THORN ROSE | 180X270 CM



**R** REPETERBAR/REPEATABLE - FOR LARGER WALL THAN 180 CM, BUY 2 OR MORE MURALS



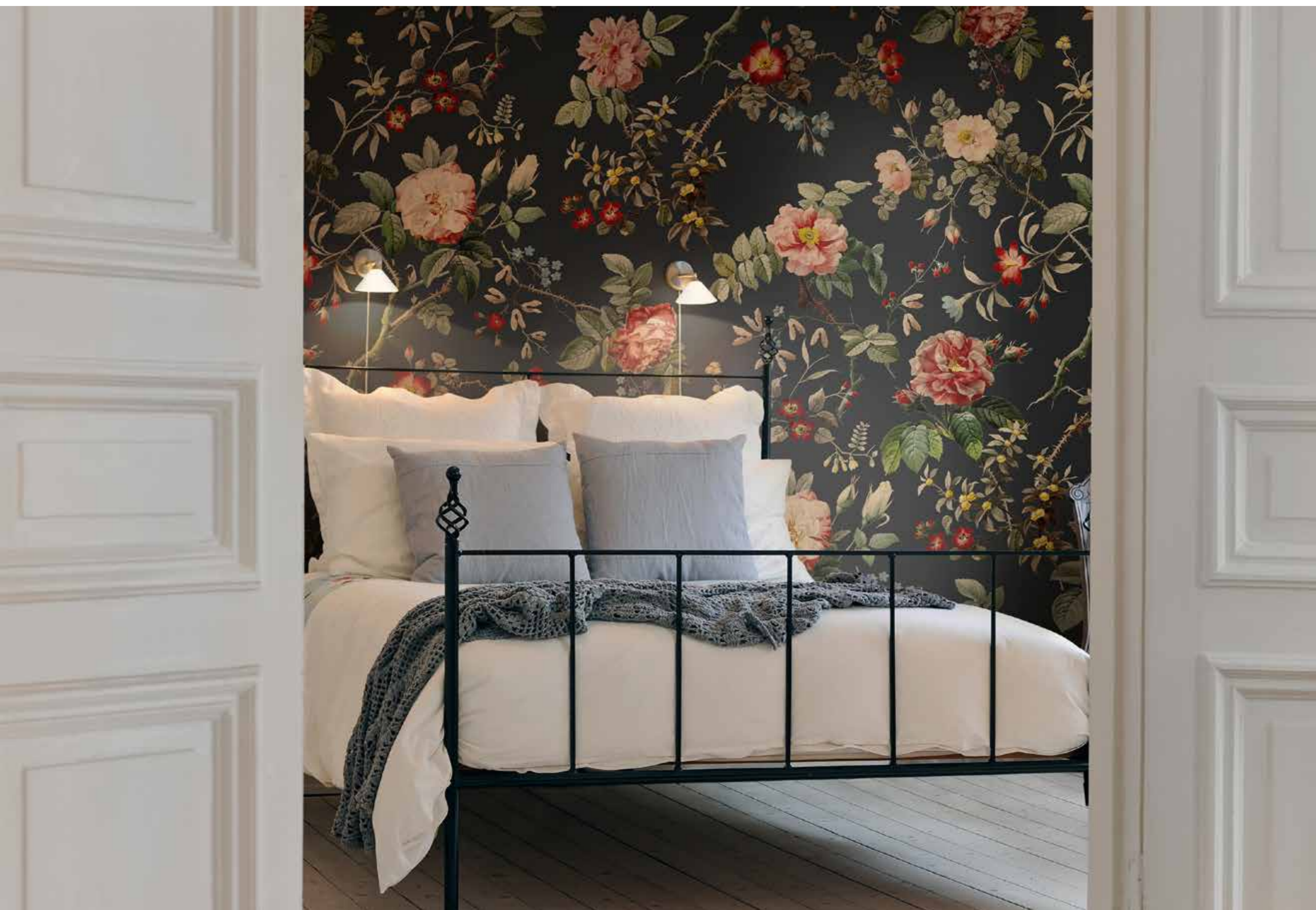



# ROSEGARDEN



R13071-5 | ROSEGARDEN | 225X270 CM

This beautiful hundred-year-old piece of art is the original drawing for a wallpaper pattern. We have kept all the details of the original just as it was. Everything from the meticulously painted raindrops to the stains and tares on the edges.

Tips! Let the wallpaper be a focal point on your wall and hang it like a piece of art.



R13072-5 | ROSEGARDEN, BLACK | 225X270 CM





SOCIETY  
SOCIETY



## WALL GARDEN

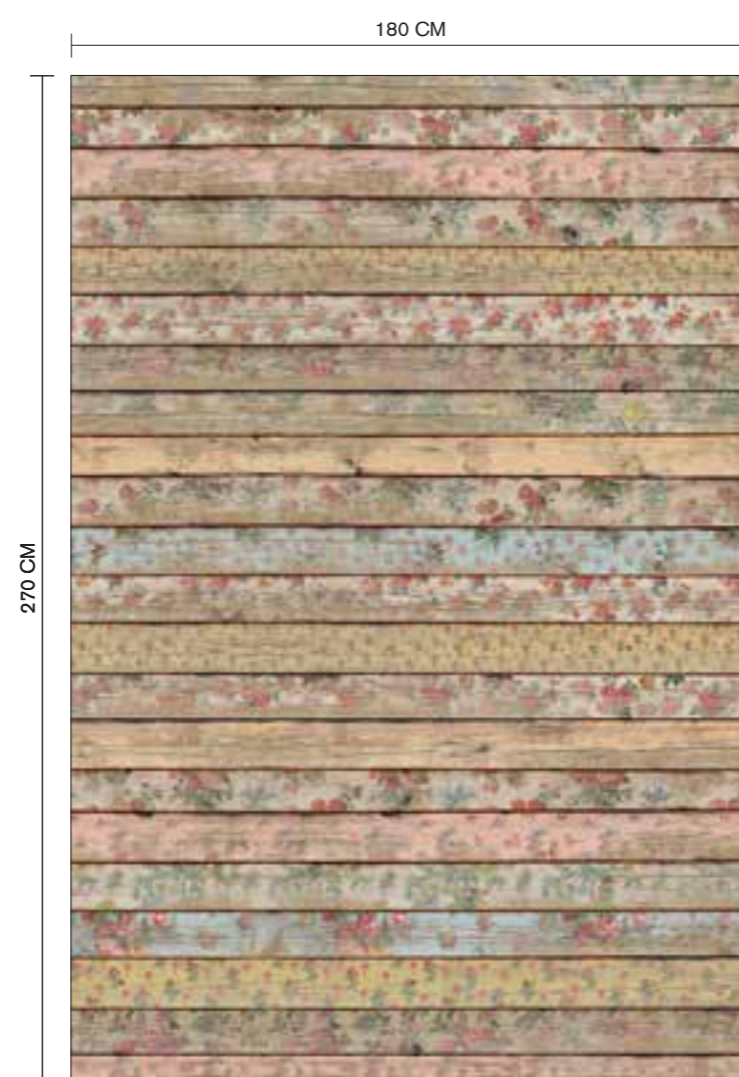

R13181-4 | WALL GARDEN | 180X270 CM

For this design we combined vintage flower patterns with weathered wooden boards. The hand drawn flower patterns were salvaged from old wallpaper factories in France. We decided to give them a new home in our Greenhouse collection.



R13181-8 | WALL GARDEN | 360X270 CM







# GROWING WILD



R13211-5 | GROWING WILD | 225X270 CM

Traditional wallpaper craftsmanship up close. The original to this design is an old worn wallpaper made with surface print technique. When using this technique, ink is pushed into the paper giving it a distinct look, almost blurry with bleeding colors. Today we use a digital printing technology that gives crisp and detailed pictures, that allows us to salute the old techniques and show them off in detail.



13212-4 | GROWING WILDERNESS | 180X270 CM

**R** REPETERBAR/REPEATABLE - FOR LARGER WALL THAN 180 CM, BUY 2 OR MORE MURALS







**FOREST  
ESCAPADES**





SCANDINAVIAN LIGHT  
SIDA/PAGE: 52-53



OLD PINE TREES  
SIDA/PAGE: 56-57



WELCOME TO THE JUNGLE  
SIDA/PAGE: 46-47

## FOREST ESCAPADES

The green forest is a constant source of inspiration. Here you will find freedom and peace of mind. It's also a place of adventure and boost of energy. Getting lost in the wilderness may help you find your true destination.



BIRCH TRUNKS  
SIDA/PAGE: 48-49



FROST LEAF  
SIDA/PAGE: 50-51



# WELCOME TO THE JUNGLE



R13041-5 | WELCOME TO THE JUNGLE | 225X270 CM

You know where you are? You're in the jungle! Or perhaps at home. Either way this wallpaper design is covered with leaves from the trendy Monstera plant and will bring all that amazing chlorophyll-green color inside.



R13041-8 | WELCOME TO THE JUNGLE | 360X270 CM







# BIRCH TRUNKS

360 CM



270 CM

R13031-8 | BIRCH TRUNKS | 360X270 CM







# FROST LEAF

360 CM



270 CM

R12941-8 | FROST LEAF | 360X270 CM







## SCANDINAVIAN LIGHT

360 CM



270 CM

R12971-8 | SCANDINAVIAN LIGHT | 360X270 CM







## LAY IN THE HAY

360 CM



270 CM

R12961-8 | LAY IN THE HAY | 360X270 CM



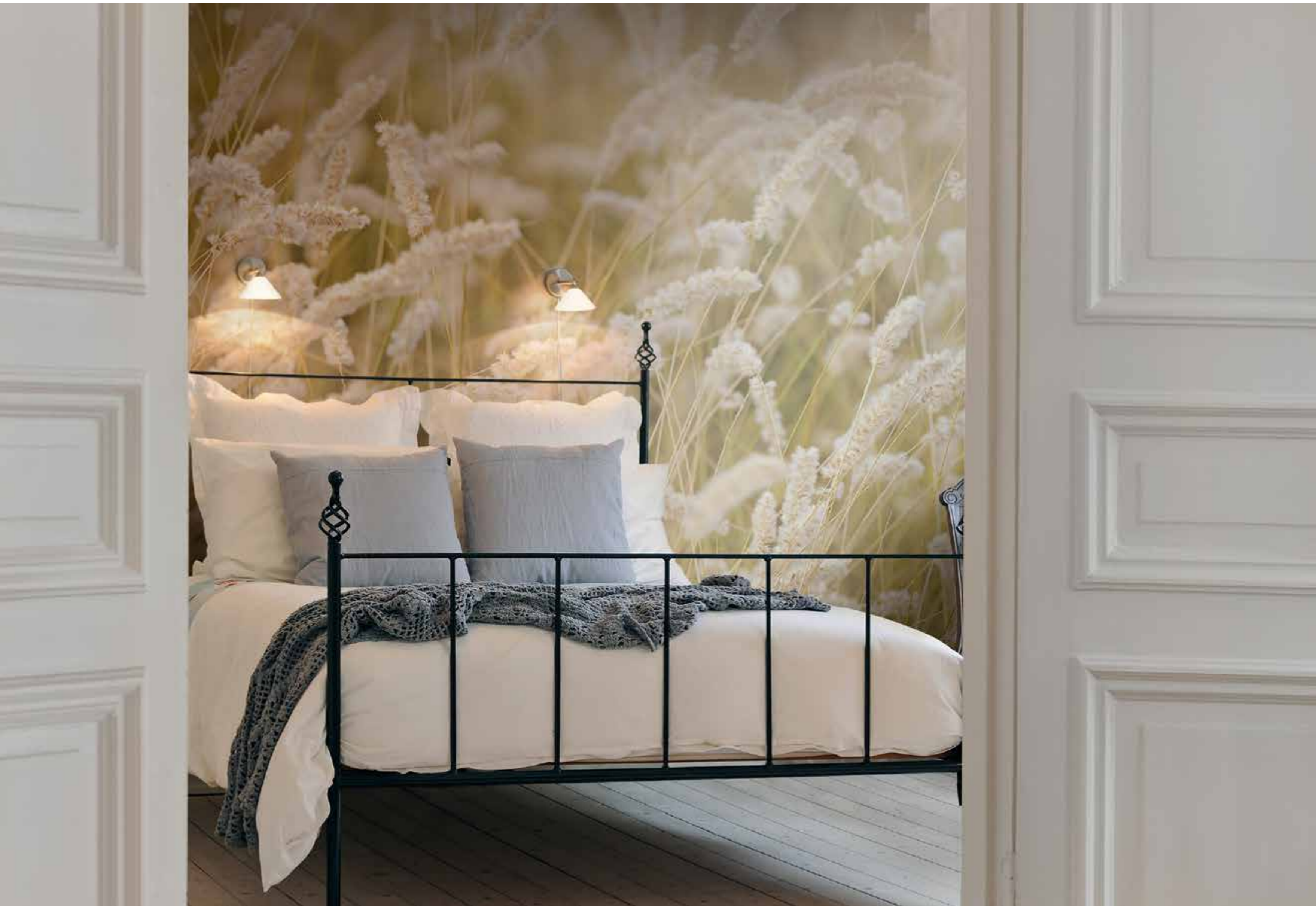



# OLD PINE TREES

360 CM



270 CM

R13021-8 | OLD PINE TREES | 360X270 CM







**STRUCTURED  
CREATIVITY**





HARLEQUIN ROSES  
SIDA/PAGE: 70-71

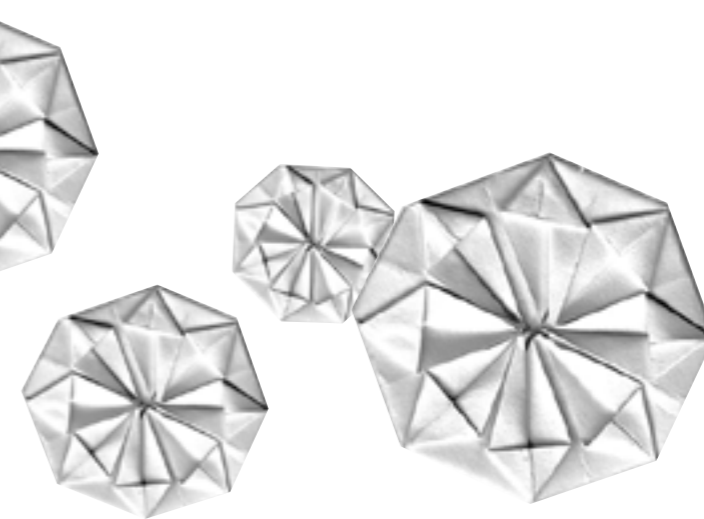

CONCRETE ROSES  
SIDA/PAGE: 68-69

## STRUCTURED CREATIVITY

There is such beauty in the intelligence of a graphical design. It's the beauty of structure. It's where chaos meets order and lives in perfect harmony.



FLOWER DOT  
SIDA/PAGE: 60-61



LILY POND  
SIDA/PAGE: 64-65



POP ART ANDY  
SIDA/PAGE: 62-63



# FLOWER DOT

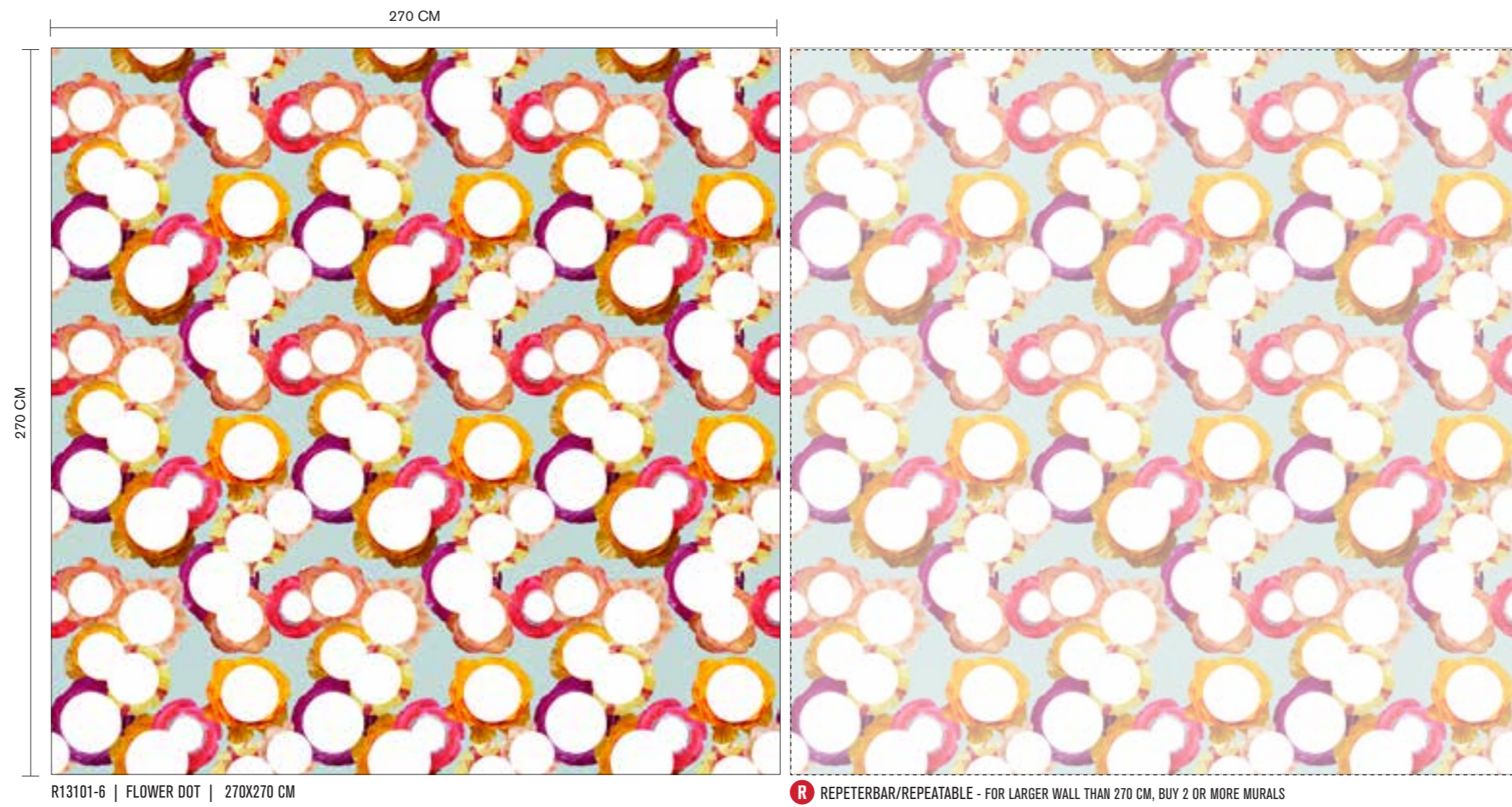

Sometime the inability to choose opens up new possibilities. We like flowers and graphical prints, but we hate to limit ourselves to only one option. Therefore we created Flower Dot - a floral wallpaper in a graphic style. The hearts of the flowers are hidden behind circles.

Tips! Make the wallpaper more personal, add some photographs to the circles.

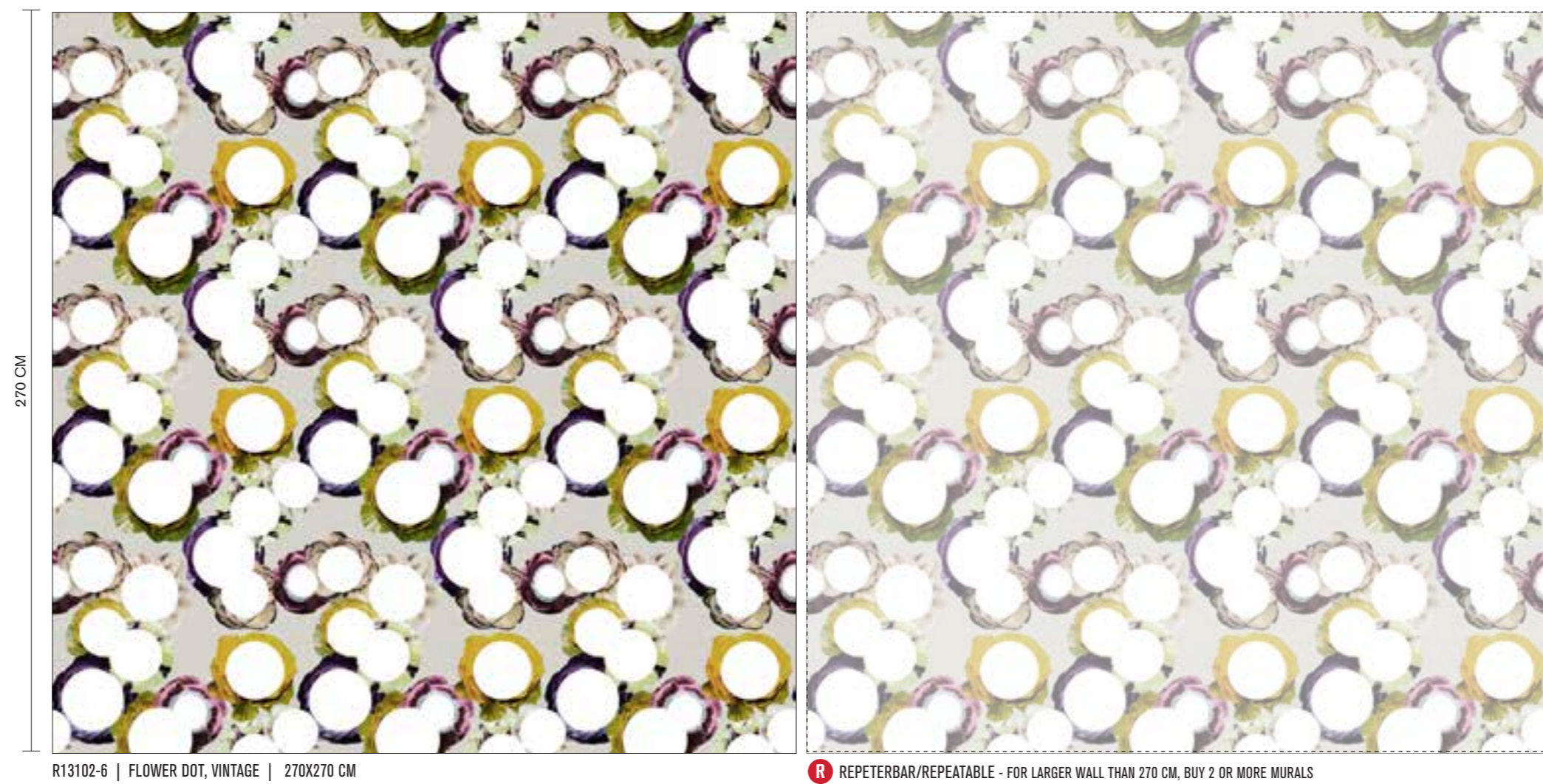







# POPPY ART ANDY



R13151-4 | POPPY ART ANDY | 180X270 CM



R13151-8 | POPPY ART ANDY | 360X270 CM







# LILY POND



R13121-6 | LILY POND, RAINBOW | 270X270 CM

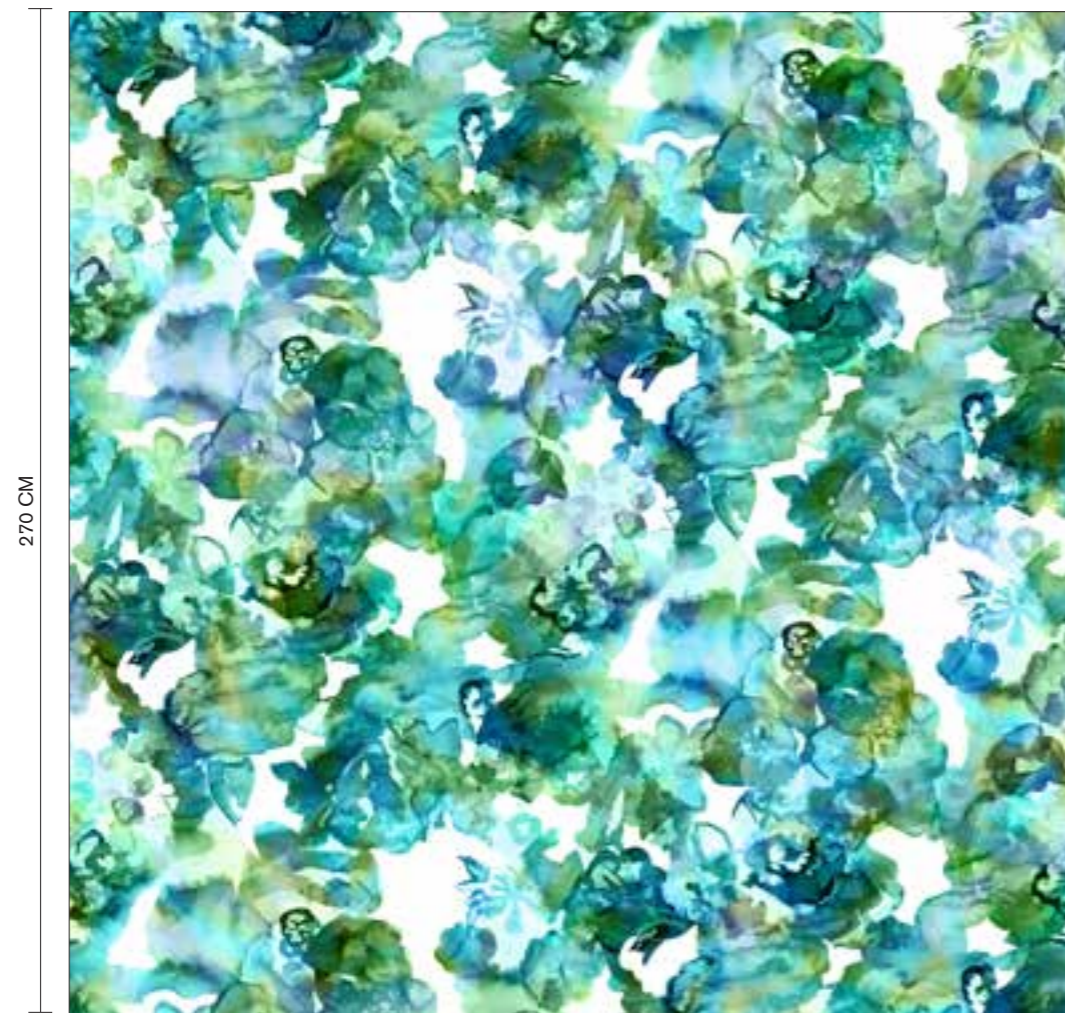

R13122-6 | LILY POND | 270X270 CM



R13123-6 | LILY POND, RED | 270X270 CM





SOCIETY  
SOCIETY



# FLORIGAMI

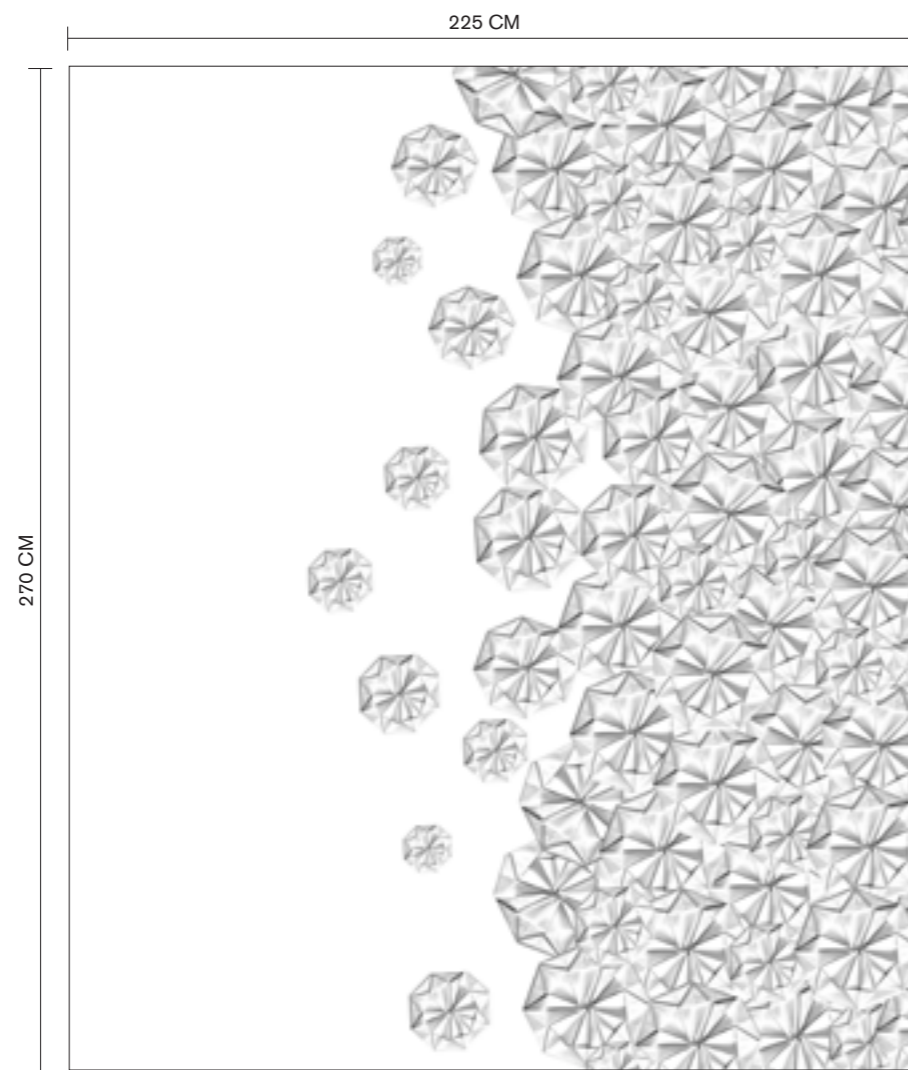

R13201-5 | FLORIGAMI | 225X270 CM

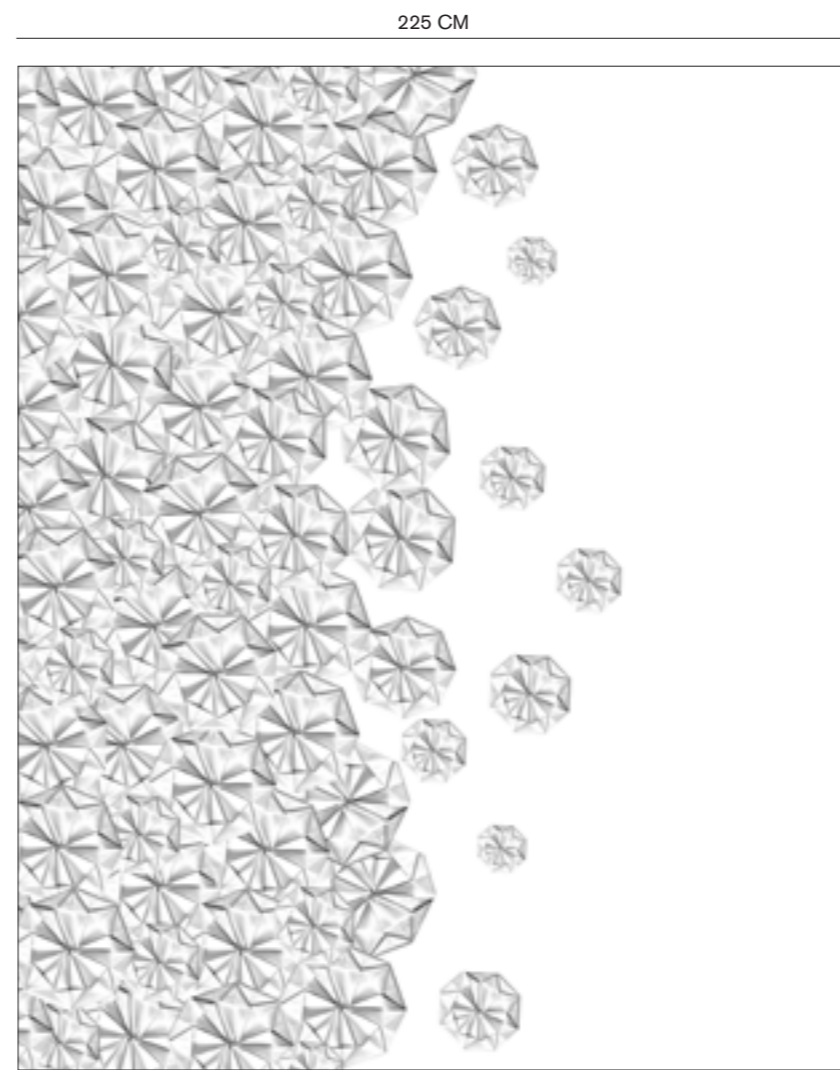

R13203-5 | FLORIGAMI | 225X270 CM

This pattern is made out of folded origami flowers.

Tips! For a cool effect, let the flowers grow out of the corner of the room by hanging the two mirrored versions side by side.

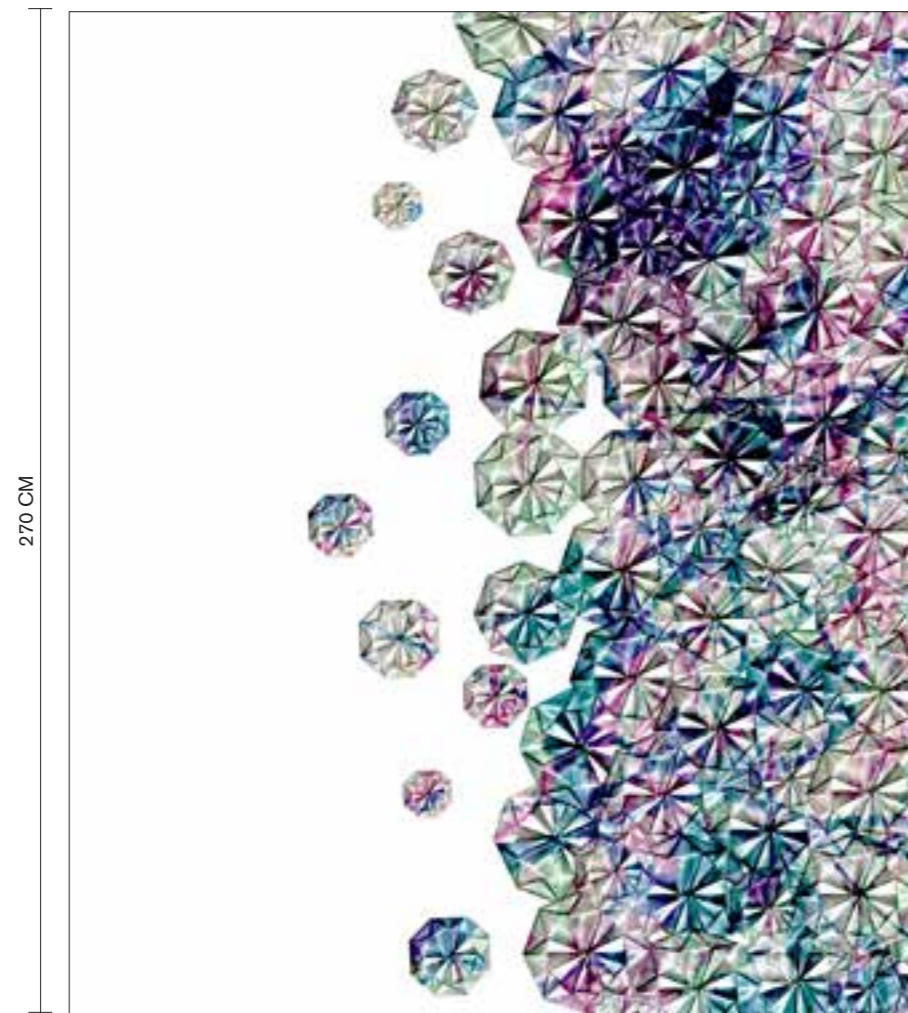

R13202-5 | FLORIGAMI, COLOR | 225X270 CM

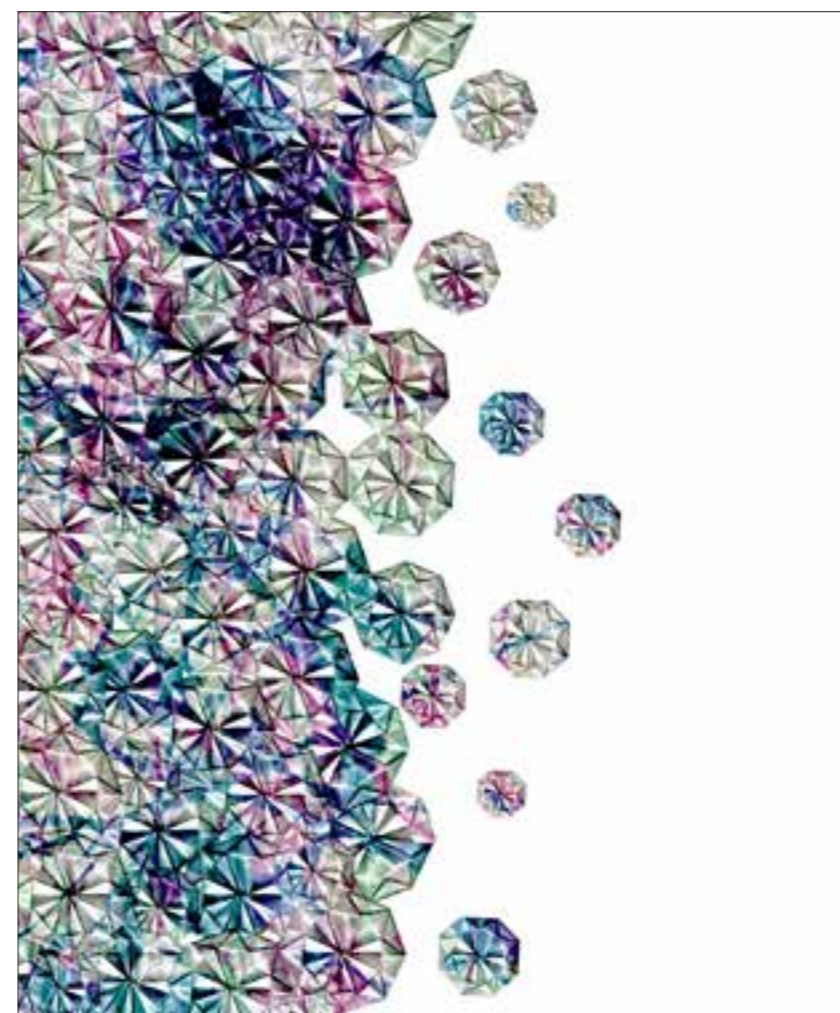

R13204-5 | FLORIGAMI, COLOR | 225X270 CM







## CONCRETE ROSES

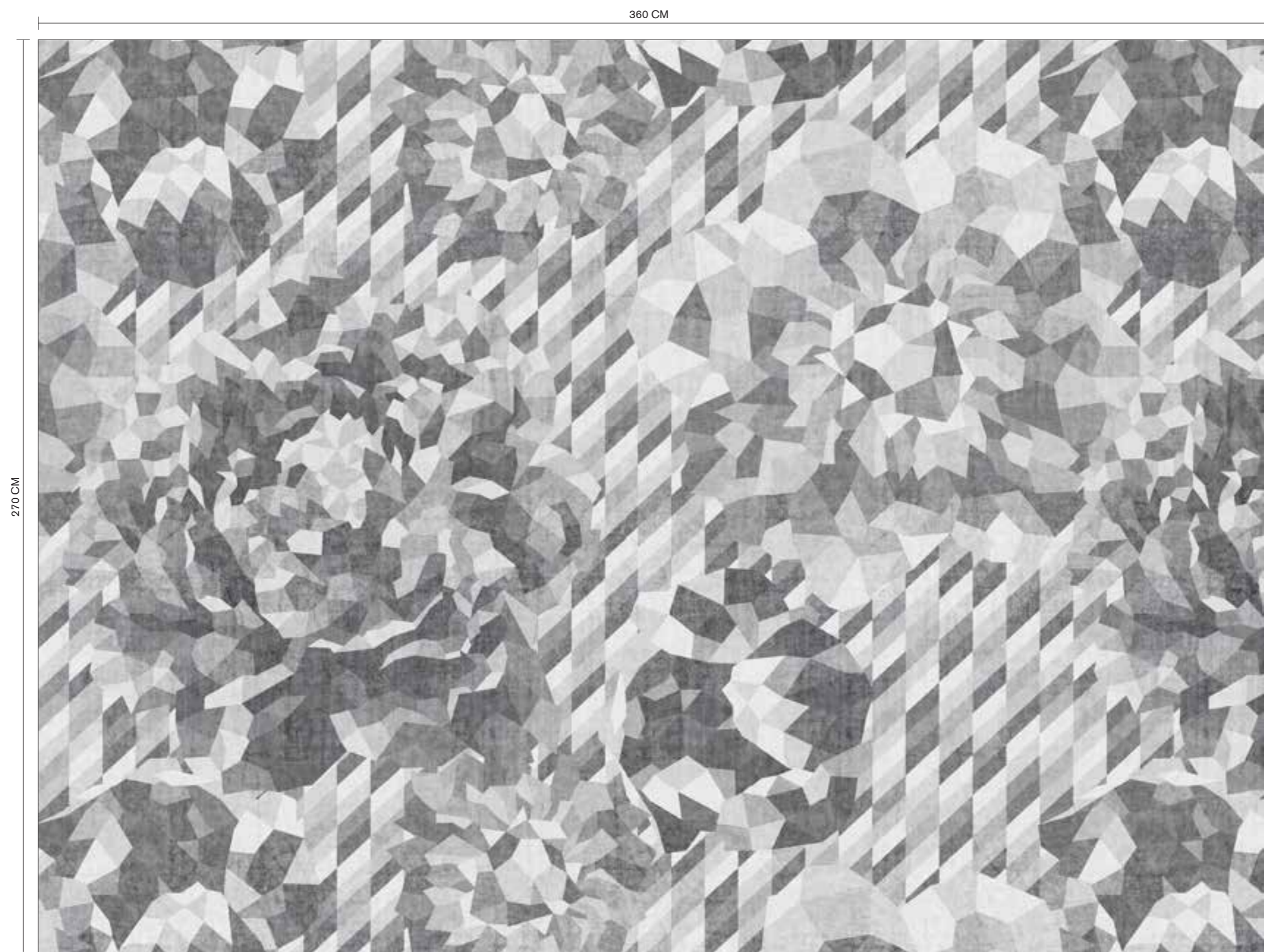

R13081-8 | CONCRETE ROSES | 360X270 CM







# HARLEQUIN ROSES

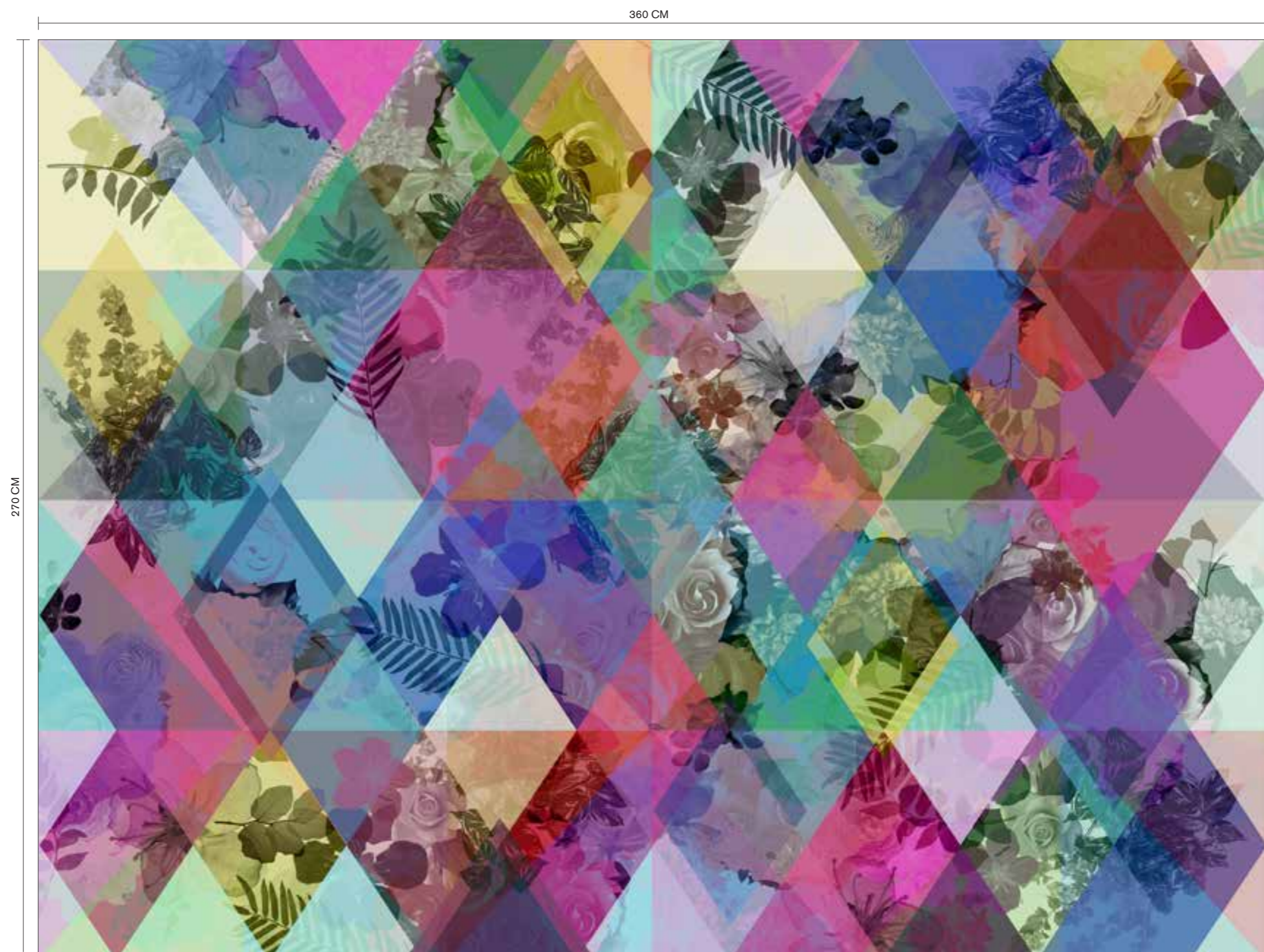

R13231-8 | HARLEQUIN ROSES | 360X270 CM







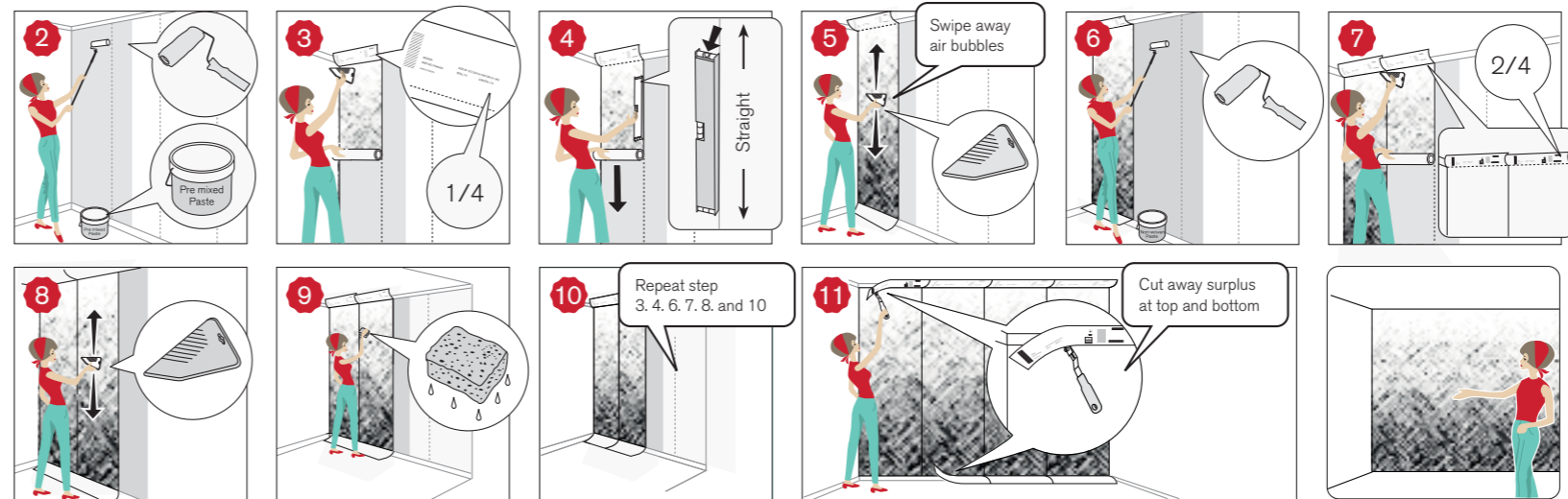
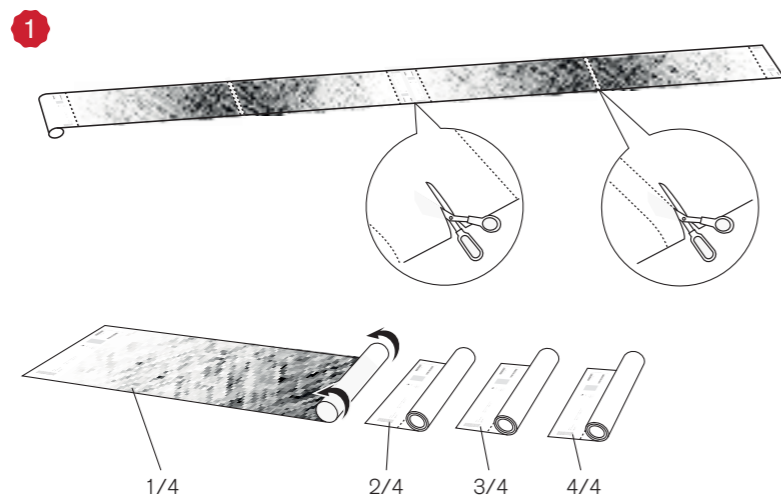
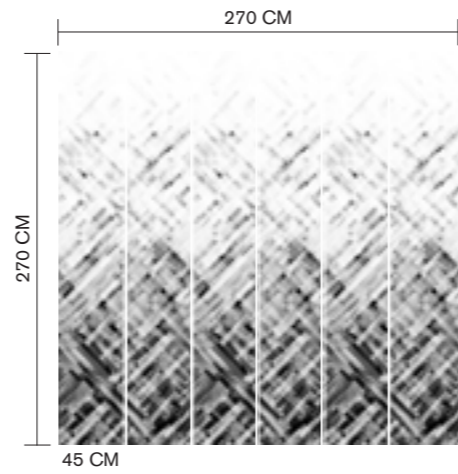

## FÖRE TAPETSERING

Väggen ska vara slät, ren, torr och väl förankrad. Gammal färg och tapet som inte sitter fast måste tas bort och spacklas vid behov. Grundmåla om väggen har starka färgskiftningar. Förlimma om underlaget är starkt sugande som exempelvis en gipsvägg.

## REKOMMENDERADE VERKTYG

- Roller & Tråg
- Hink
- Pensel (Där rollern inte kommer åt t.ex. vid tak och lister)
- Vattenpass eller Lod (För att kontrollera att tapetväden hänger rakt)
- Ställinjal (För ev. stöd vid renskärning vid golv och tak)
- Tapetsvamp (Mjuk trasa eller svamp, helst cellulosesvamp)
- Bjlyrtspenna
- Tapetkniv
- Tapetverktyg eller borste.

**RÄTT LIM** Använd alltid lim specifikt för non-woven tapeter.

## MONTERING AV TAPET 1 → 11

Börja med att dela isär väderna enligt skärmarkeringarna. Lägga väderna sedan med etiketten uppåt i nummerordning med våd nr. 1 först. Kontrollera att alla väder är med och ingen våd är defekt eller skadad.

2-10. Alla väder är numrerade i den följd de ska monteras. Väderna ska monteras kant i kant vilket innebär att de inte ska överlappas. Det är viktigt att första väden monteras rakt. Tips är att göra ett lodat bjlyrtstreck, en tapetvåd in på väggen och sedan montera första väden längst med bjlyrtstrecket.

Rolla lim direkt på väggen. Se till att hela ytan täcks med lim och att det blir ett jämnt lager, en olimmad fläck blir en blåsa på tapeten. Limma 1,5 tapetvåd i taget. Se till skjuta ihop väderna utan några synliga skarvar med ett lätt och jämnt tryck. Se till att det finns lim där vädkanterna möts annars kan skarvorna bli synliga. Undvik att få lim på fämsidan av tapeten och skölj eventuella limrester omgående med en rikligt blöt tapetsvamp.

Eftersläta varje våd med ett rent tapetverktyg eller tapetborste. Arbeta från tak mot golv och från mitten mot kanterna.

11. När hela tapeten är på plats skär bort överflödigt tapet vid golv och tak. Ha alltid vassa blad för att inte trasa sönder tapeten. Vädra rummet i 1 dygn men håll normal rumstemperatur så limmet torkar.



## BEFORE YOU BEGIN

The surface of the wall must be smooth, clean, dry and sound. Flaking paint and loose wallpaper should be removed and any uneven surfaces must be filled. Give the wall a prime coating if the colour of the wall is very different to the new wallpaper. Very absorbent surfaces, such as plaster walls, should be sized.

## RECOMMENDED TOOLS

- Rollers and tray
- Bucket
- Paintbrush (For the areas that the roller misses, e.g. along the ceiling and skirting boards)
- Spirit level or plumb line (To make sure the wallpaper is straight)
- Steel ruler (To make a straight, clean cut along the top and bottom)
- Wallpaper sponge (Soft cloth or sponge, preferably a cellulose sponge)
- Pencil
- Craft knife
- Wallpapering tool or brush

**RIGHT ADHESIVE** Always use an adhesive specially recommended for non-woven wallpaper.

## HANGING WALLPAPER 1 → 11

Start by dividing the lengths as indicated by the cutting symbols. Lay the lengths, with the label facing upwards, in numerical order starting with length number 1. Make sure you have all the lengths and that none of them are defective or damaged.

2-10. The lengths are numbered in the order in which they must be hung. The lengths should be hung edge to edge without any overlapping. It is essential that the first length is vertically straight. Tip: Make a pencil mark one wallpaper width along the wall near the ceiling. Hold a plumb line on the mark and draw a vertical line down the wall. Then line up your first length of wallpaper with this pencil line.

Roll the paste straight onto the wall. Be sure to evenly cover the entire surface. If you miss a spot, this will cause the wallpaper to bubble. Paste an area the width of one and a half lengths at a time. Gently and evenly press the lengths together to ensure there are no visible seams. Make sure the wall has been pasted where the lengths meet so that the edges are not visible. Try not to get paste on the front of the wallpaper. Any excess paste should be removed immediately using a wet wallpaper sponge.

Smooth each length with a clean wallpapering tool or wallpaper brush. Work from the ceiling to the floor and from the middle out to the edges.

Once all the wallpaper has been hung, cut off any excess along the ceiling and floor. Always use a sharp blade to avoid tearing the paper. Keep the room ventilated and at normal room temperature for 24 hours to allow the paste to dry.



## FØR TAPETSERING

Veggen skal være jevn, ren, tørr og godt festet. Gammel maling og tapet som ikke sitter fast, må fjernes og sparkles ved behov. Bruk grunning hvis veggen har sterke fargeforskjeller. Hvis underlaget er kraftig absorberende, som for eksempel en gipsvegg, bør du forlime.

## ANBEFALT VERKTØY

- Malerulle og malerullkar
- Bøtte
- Pensel (brukes der malerullen ikke kommer til, f.eks. ved tak og lister)
- Vatterpass eller lodd (for å sjekke at tapetlengden henger rett)
- Stållinjal (for ev. støtte ved renskæring ved golv og tak)
- Tapetsvamp (myk klut eller svamp, helst cellulosesvamp)
- Blyant
- Tapetkniv
- Tapetsparkel eller -børste

**RIKTIG LIM** Bruk alltid lim som er beregnet på non-woven-tapeter.

## MONTERING AV TAPET 1 → 11

Begynn med å dele lengdene i henhold til skjæremarkeringene. Legg deretter lengdene med etiketten opp i nummerrekkefølge, med lengde 1 først. Kontroller at alle lengdene er med, og at ingen av lengdene er defekte eller skadet.

2-10. Alle lengdene er nummerert i den rekkefølgen de skal monteres. Lengdene skal monteres kant i kant og skal ikke overlappe hverandre. Det er viktig at den første lengden monteres rett. Et tips er å tegne en lodrett blyantstrek én tapetlengde inn på veggen og deretter montere den første lengden langs streken.

Påfør lim direkte på veggen. Sørg for at hele overflaten dekkes med lim, og at det blir et jevnt lag. Felter uten lim, danner en blære i tapetet. Påfør lim til 1,5 tapetlengde av gangen. Pass på å sette sammen lengdene uten synlige skjøter og med et lett, jevnt trykk. Pass på at det er lim der tapetkantene møtes, hvis ikke kan skjøtene bli synlige. Unngå å få lim på farsiden av tapetet. Eventuelle limrester må tørkes av med én gang med en godt fuktet tapetsvamp.

Glatt over hver lengde med en ren tapetsparkel eller -børste. Arbeid fra tak mot golv og fra midten mot kantene.

Når hele tapetet er på plass, skjærer du bort overflødig tapet ved golv og tak. Sørg for at tapetkniven har skarpe blader, slik at ikke tapetkanten blir fliset. Luft ut rommet i 1 døgn, men hold normal romtemperatur, slik at limet tørker.



## FØR TAPETSERING

Væggen skal være glat, ren, tør og godt forankret. Gammel maling og tapet, som ikke sidder fast, skal fjernes og spartles efter behov. Giv væggen grundmaling, hvis den har stærke farveforskelle. Forlim, hvis underlaget er stærkt sugende, som for eksempel en gipsvæg.

## ANBEFALEDE VÆRKTØJER

- Malerulle og bakke
- Spand
- Pensel (Hvor malerullen ikke kan komme til, f.eks. ved loft og lister)
- Vatterpass eller lod (For at kontrollere, at tapetbanen hænger lige)
- Stållineal (Til eventuel støtte ved renskæring ved golv og loft)
- Tapetsvamp (Blød klud eller svamp, helst cellulosesvamp)
- Blyant
- Tapetkniv
- Tapetspartel eller tapetbørste

**DEN RETTE LIM** Benyt altid lim, der er specifikt beregnet til non-woven tapeter.

## OPSÆTNING AF TAPET 1 → 11

Begynd med at dele banerne i henhold til skæremarkeringerne. Læg derefter banerne med etiketten opad i nummerrekkefølge, med bane nr. 1 først. Kontroller, at du har alle baner, og at ingen af banerne er defekte eller beskadigede.

2-10. Alle baner er nummereret i den rækkefølge, de skal monteres. Banerne skal monteres kant mod kant, hvilket betyder, at de ikke skal overlappes. Det er vigtigt, at den første bane hænger lige. Et tip er at tegne en lodret blyantstreg en tapetbane inde på væggen og derefter sætte den første bane op langs med blyantstregen.

Rul limen direkte på væggen. Sørg for, at hele overfladen dekkes med lim, og at laget påføres jævnt. En plet uden lim giver en blære på tapetet. Rul lim på til 1,5 tapetbane ad gangen. Sørg for at skyde banerne sammen uden nogen synlige samlinger med et let og jævnt tryk. Sørg for, at der er lim, hvor banekanterne mødes, da samlingerne ellers kan blive synlige. Undgå at få lim på farsiden af tapetet, og tør straks eventuelle limrester af med en godt vædet tapetsvamp.

Glæt hver bane efter med en ren tapetspartel eller tapetbørste. Arbejd fra loftet mod gulvet og fra midten mod kanterne.

Når hele tapetet er kommet på plads, skæres overflødig tapet væk ved golv og loft. Sørg for, at tapetkniven altid har skarpe blade for at undgå flossede tapetkanter. Luft rummet ud i 1 døgn, men bevar normal rumtemperatur, så limen tørrer.



## ENNEN TAPETOINTIA

Seinän tulee olla siileä, puhdas, kuiva ja luja. Poista irtomaali ja -tapetit ja silota seinä tarvittaessa. Pohjamaalaa seinä, jos siinä on suuria silyveroja. Esiliimaa voimakkaasti imevä alusta kuten esimerkiksi kipsiseinän.

## SUOSITELTAVAT TYÖKALUT

- Tela ja kaukalo
- Sanko
- Sivellin (paikkoihin, joihin telalla ei pääse esim. katonrajat ja listanviusstat)
- Vesivaaka tai luotilanka (tapettivuodan pystysuoruden tarkastamiseen)
- Teräsviivain (avuksi tapetin leikkaamiseen lattian ja katonrajassa)
- Sieni (Pehmeä riepui tai sieni, mieluiten selluloosasieni)
- Lyijykynä
- Tapettiveitsi
- Tapettilasta tai harja

**OIKEA LIIMA** Käytä aina non-woven-tapeteille tarkoitettua liimaa.

## TAPETIN ASENNUS 1 → 11

Aloita leikkaamalla vuodat leikkausmerkkien mukaan. Aseta vuodat sitten etiketti ylöspäin numerjärjestykseen, 1. vuoda päällimmäiseksi. Tarkasta, että kaikki vuodat ovat mukana ja että kaikki ovat ehjä.

2-10. Vuodat on numeroitu asennusjärjestyksessä. Vuodat asennetaan puskusumoin, ts. ne eivät saa olla limittini. On tärkeää, että ensimmäinen vuoda asennetaan pystysuoraan. Vedä ensin pystysuora lyijykynäviiva seinälle yhden vuodan päähän nurkasta ja asenna sitten ensimmäinen vuoda lyijykynäviivan viereen.

Levitä liima suoraan seinälle. Varmista, että liima peittää koko pinnan tasaisena kerroksena, liimaton kohta jättää kuplan tapettiin. Liimaa 1,5 vuotaa kerrallaan. Työnnä vuotia yhteen kevyesti ja tasaisesti päinaen niin, että niiden välin ei jää näkyviä saumoja. Varmista, että vuodien reunoissa on liimaa, muuten saumat saattavat jäädä näkyviin. Älä päästä liimaa tapetin etupinnalle ja pyyhi liimajäänteet välittömästi määrällä tapettiseinellä.

Kiinnitä jokainen vuoda puhtaalla tapettilastalla tai -harjalla. Työkentele ylhäältä alas päin ja etene keskeltä reunoja kohti.

Kun koko tapetti on paikallaan, leikkaa ylimääräinen tapetti lattian ja katon rajasta. Käytä terävää tapettiveistä, jotta tapetti ei repeydy. Tuuleta huonetta vuorokauden ajan, mutta pidä se normaalissa huonelämpötilassa, jotta liima kuivuu.





BE A REBEL - MAKE A DIFFERENCE